

Dimmer Switch

MH-DT411

Introduction

Dimmer Switch is a wall panel built-in with Z-Wave Plus module. With its stylish design and stable performance, the panel can be used to control the light level. It supports basic command class, multi channel command class and multi channel association command class, also works as a repeater in a Z-Wave network. This product can be included and operated in any Z-Wave network with other Z-Wave certified devices from any other manufacturers.

Specifications

- Power supply: 85~260VAC, 50/60Hz
- Output: 1* 20-200W
- Z-Wave frequency: 868.42MHz(EU), 908.42MHz(US), 921.4MHz(AU) or other frequency customized

Installation Instructions

IMPORTANT:

- A qualified electrician with the understanding of wiring diagrams and knowledge of electrical safety should complete the installation inside the main circuit box (normally outside your house).
- Read all instructions and documentation and save for future reference.

CAUTION: Cut off power supply at circuit breaker or fuse before installation to avoid fire, shock or death!

Installation

Wiring (standard strip length: 6-8mm)

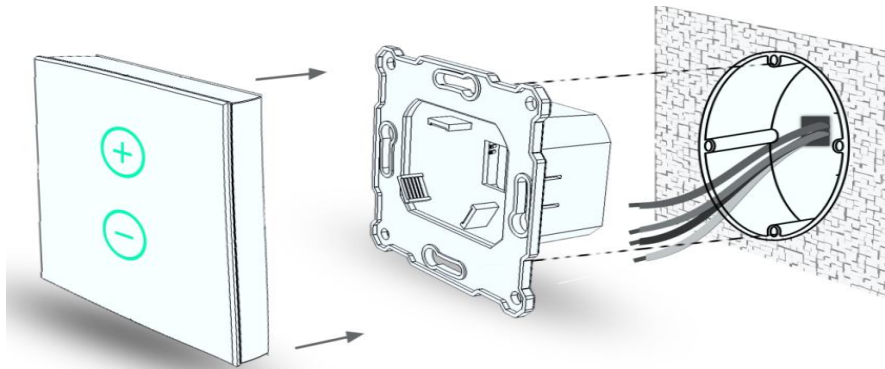

Step 1: Separate the device into two parts: the touch panel and the bottom.

Step 2: Insert all wires into the right terminals by following the wiring diagrams as below, and tighten screws.

Step 3: Secure the bottom part onto a junction box with screws, and then mount the touch panel back.

Step 4: Confirm the device is well mounted, power on and it is ready to operate.

Note: S1, S2, Sx are optional terminals for an external dimmer panel input.

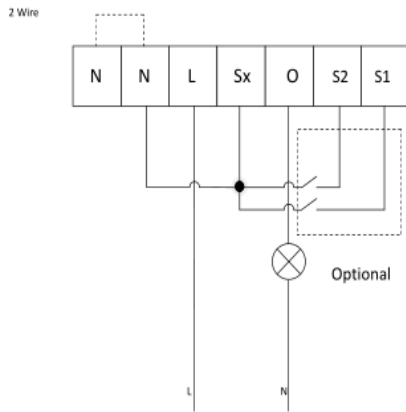

2-wire

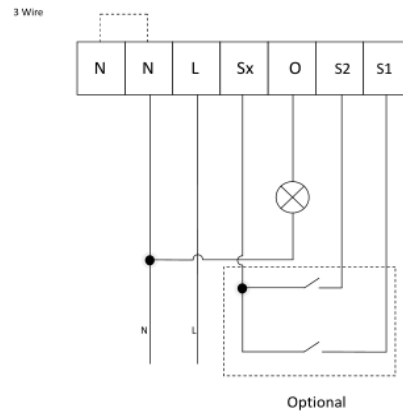

3-wire

Operation

Adding / Removing:

1. Set controller into Add/Remove mode, and press 3 clicks on "+" or "-" button to add/remove. If succeed, green LED flicks 4 times.
2. If an external switch panel wired, press/toggle the button on that panel 3 times also can add /remove the network (To make the external panel work, set the parameter 0X0E with value 1, 2, 3 or 4).

Dimming Mode Setting:

The panel can be manually configured or automatically detect different light source by following the steps as below:

1. Touch "+" 4 times and its green LED flashes, then touch "-" 4 times and 2 green LEDs flash for 3 sec. The panel enters Dimming mode setting.
2. During setting, the "+" LED color will inform the current dimming mode:

Leading edge for inductive loads	Trailing edge for capacitive or resistive loads	On/off only	Automatically detection
Orange LED flashing	Green LED flashing	Orange and Green LEDs flashing together	Orange and Green LEDs flashing alternately

3. Touch "-" will switch among the four modes :

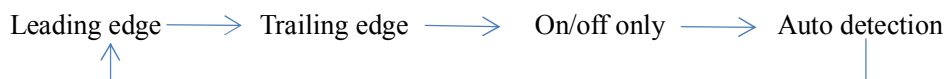

4. Touch "+" to confirm the mode you chose, the mode's LED color will flash 3 sec to finish the setting. If Auto detection chosen, pls wait the panel to detect the light source and confirm leading edge or trailing edge dimming itself.

Manual Operation:

1. When powered on, hold "+/-" button will dimming the light level up or down.(Not valid when the dimming mode is “on/off only”)
2. Double click of “+” will turn on the light to the brightness level, and double click of “-” will turn off the light.

Energy Consumption Monitoring:

When requested by controller, the panel will report voltage, current and power consumption (the command class which support this function is Meter Command Class).

The dimming percentage when single touch of button “+” or “-”

1. Parameter 0x0B is used to set the value.
For instance: The current light level is 0, and the set value is 0x10. When first single touch “+”, the light level will reach 0x10, and the second single touch of “+” will make the level reach 0x20, single touch “-” will make it back to 0x10 again.
2. Hold the “+” or “-” and release, the changed light level percentage during the holding will be saved and performed in the next single touch dimming.

Notification:

1. Parameter 0x20 and 0x21 are used to set the notification threshold.
2. When enabled, device will send unsolicited notification frame to gateway.

Association Group:

To set association groups by the command “COMMAND_CLASS_MULTI_CHANNEL_ASSOCIATION”.

The device supports 4 association groups (AG). The 1st AG is used for reporting devices’ state to the controller if any changes happen. This group supports one Node, which suggested to be controller Node. The rest AGs are used for switching associated devices, and each can support up to 5 nodes.

AG NO.	Function	Explanation
0x01	Associate with gateway	Send unsolicited reports to the gateway
0x02	Associate with the panel	Send Switch_Multilevel CC to associated devices
0x05	Associate with Key “+”	Send Basic Set CC to associated devices
0x08	Associate with Key “-”	

Parameters Setting:

Add	Function	Byte	Options	Default	Remark
0x01	Dimmer state saved or not when power down	1	0x00 not saved, Dimmer will be off when powered again 0x01 saved, Dimmer will keep the same state when powered again	0x00	
0x02	Dimming mode	1	0x00 leading edge 0x01 trailing edge 0x02 On/off only	0x01	

0x03	Auto detection of dimming mode when powered on	1	0x00 Auto detection disabled 0x01 Auto detection enabled	0x01	
0x04	LED Backlit brightness level	1	0x00 LED disabled 0x01~0x0A Min level-Max level	0x0a	
0x05	Minimum brightness level	1	1~98 percentage brightness level	0x01	The max level should always higher than min level
0x06	Maximum brightness level	1	2~99 percentage brightness level	0x63	
0x07	Single dimming step time(Manual)	2	Max 2.55s, in 10ms steps	0x03 (30ms)	
0x08	Single dimming step size(Manual)	1	1~99 percentage value (modification isn't recommended)	0x01	
0x09	Single dimming step time (Auto)	2	Max 2.55s, in 10ms steps	0x03 (30ms)	
0x0A	Single dimming step size (Auto)	1	1~99 percentage value (modification isn't recommended)	0x01	
0x0B	The dimming percentage when single touch of button "+" or "-"	1	0x00 the percentage get by the last button-holding touch 1~99 percentage value	0x00	With this parameter you can set the light level the lamp will reach when you turn on the lamp of single touch "+"
0x0C	Reporting interval for dimming level	1	0 : No report during dimming send report in 1-255*10ms interval	0x0A	
0x0D	External switch type	1	0x00 Button (Momentary buttons) 0x01 Toggle (2-state Switches)	0x00	
0x0E	External switch input	1	0x00 function disabled 0x01 wire 1 ex.switch key to S1 only 0x02 wire 1 ex.switch key to S2 only 0x03 wire 2 ex.switch keys to S1 and S2,each key can control both dimming directions 0x04 wire 2 ex.switch keys to S1 and S2, each key control one dimming direction	0x00	
0x0F	Energy meter reporting	1	Watt (bit 0): 0: disabled 1: enabled KWH (bit 1): 0: disabled 1: enabled Ampere (bit 2): 0: disabled 1: enabled Voltage (bit 3): 0: disabled 1: enabled	0x00	
0x10	Energy meter reporting interval	1	n*1sec	0x10	

0x11	Beep	1	0x00 beep disabled 0x01 beep enabled	0x01	
0x20	Ampere alarm threshold	2	0: alarm disabled 1-5000*0.01 A alarm enabled	0x00	
0x21	Voltage alarm threshold	2	0: alarm disabled 1-10000*0.1 V alarm enabled	0x00	
FF	Factory setting	1	0x55 restore factory setting		write only

Restore Factory setting

Press 10 times of any button or exclude the device from Z-Wave network, then cut off the main power. The factory setting will be restored.

SAFETY NOTICE

1. Flush-mount only into a UL/ETL/CE certified plastic junction box and switch panel cover. The minimum size should be 65*65*45mm, minimum Volume is 190cm³.
2. Use Copper Conductors Only.
3. CAUTION - Risk of Electric Shock - More than one disconnect switch may be required to de-energize the equipment before servicing.

1-year Limited Warranty

We warrant this product to be free from defects in material and workmanship under normal and proper use for one year from purchase date of the original purchaser. We will, at its option, either repair or replace any part of its products that prove defective by reason of improper workmanship or materials. THIS LIMITED WARRANTY DOES NOT COVER ANY DAMAGE TO THIS PRODUCT THAT RESULTS FROM IMPROPER INSTALLATION, ACCIDENT, ABUSE, MISUSE, NATURAL DISASTER, INSUFFICIENT OR EXCESSIVE ELECTRICAL SUPPLY, ABNORMAL MECHANICAL OR ENVIRONMENTAL CONDITIONS, OR ANY UNAUTHORIZED DISASSEMBLY, REPAIR OR MODIFICATION. This limited warranty shall not apply if: (i) the product was not used in accordance with any accompanying instructions, or (ii) the product was not used for its intended function. This limited warranty also does not apply to any product on which the original identification information has been altered, obliterated or removed, that has not been handled or packaged correctly, that has been sold as second-hand or that has been resold contrary to Country and other applicable export regulations.