



ZWAVE-SELECTION

Temperature and Humidity sensor | PAT02-B

SKU: ZWSEMS



Quickstart

This is a **secure Multilevel Sensor for Europe**. To run this device please insert fresh **1 * CR123A** batteries. Please make sure the internal battery is fully charged.

1. Have Z-Wave Controller entered inclusion mode.
2. Pressing the tamper key three times within 1.5 seconds to enter the inclusion mode.
3. After add successful, the device will wake to receive the setting command from Z-Wave Controller about 20 seconds.

What is Z-Wave?

Z-Wave is the international wireless protocol for communication in the Smart Home. This device is suited for use in the region mentioned in the Quickstart section.

Z-Wave ensures a reliable communication by reconfirming every message (**two-way communication**) and every mains powered node can act as a repeater for other nodes (**meshed network**) in case the receiver is not in direct wireless range of the transmitter.

This device and every other certified Z-Wave device can be **used together with any other certified Z-Wave device regardless of brand and origin** as long as both are suited for the same frequency range.

If a device supports **secure communication** it will communicate with other devices secure as long as this device provides the same or a higher level of security. Otherwise it will automatically turn into a lower level of security to maintain backward compatibility.

For more information about Z-Wave technology, devices, white papers etc. please refer to www.z-wave.info.



Product Description

Temperature & Humidity Sensor

Prepare for Installation / Reset

Please read the user manual before installing the product.

In order to include (add) a Z-Wave device to a network it **must be in factory default state**. Please make sure to reset the device into factory default. You can do this by performing an Exclusion operation as described below in the manual. Every Z-Wave controller is able to perform this operation however it is recommended to use the primary controller of the previous network to make sure the very device is excluded properly from this network.

Reset to factory default

This device also allows to be reset without any involvement of a Z-Wave controller. This procedure should only be used when the primary controller is inoperable.

1. Pressing tamper key four times within 1.5 seconds and do not release the tamper key in the 4th pressed, and the LED will light ON.
2. After 3 seconds the LED will turn OFF, after that within 2 seconds, release the tamper key. If successful, the LED will light ON one second. Otherwise, the LED will flash once.
3. IDs are excluded and all settings will reset to factory default.

Safety Warning for Batteries

The product contains batteries. Please remove the batteries when the device is not used. Do not mix batteries of different charging level or different brands.

Installation

Battery Installation

When the device report the low battery message. The user should replace the battery to new one. The battery type is CR123A, 3.0V. The way to open the front cover please press the top position, to release the cover.

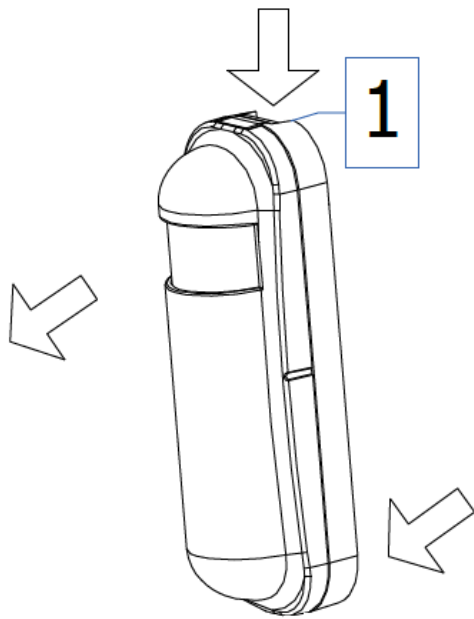

Replace the new battery and install the cover back.

1. Put the front cover bottom, and press down.
2. Push the front cover top.

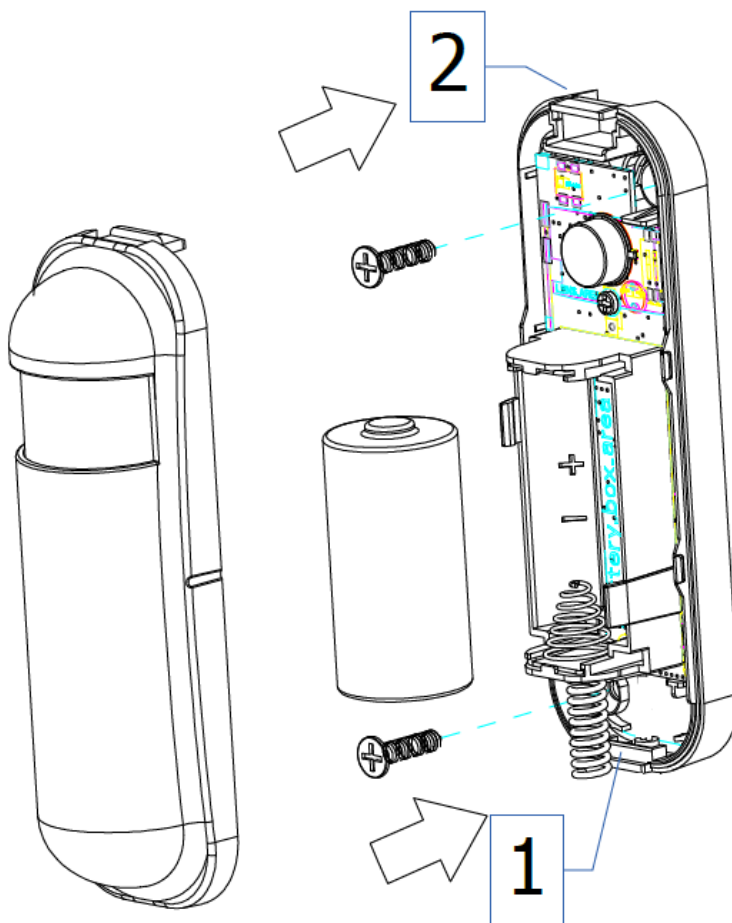

Installation

1. To mount the device on the wall, you can choose using the tape, or the screw.

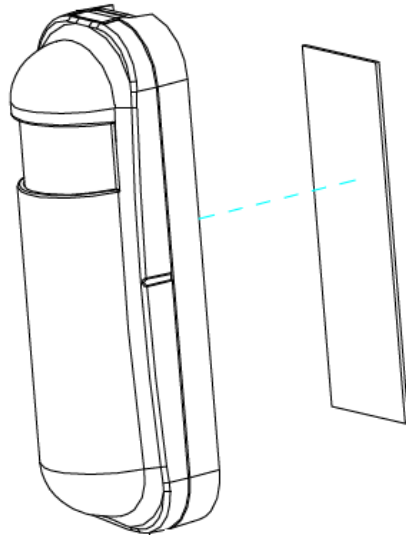

Inclusion/Exclusion

On factory default the device does not belong to any Z-Wave network. The device needs to be **added to an existing wireless network** to communicate with the devices of this network. This process is called **Inclusion**.

Devices can also be removed from a network. This process is called **Exclusion**. Both processes are initiated by the primary controller of the Z-Wave network. This controller is turned into exclusion respective inclusion mode. Inclusion and Exclusion is then performed doing a special manual action right on the device.

Inclusion

Pressing the tamper key three times within 1.5 seconds to manual inclusion with Z-Wave controller.

Exclusion

Pressing tamper key three times within 1.5 seconds to enter the exclusion mode.

Communication to a Sleeping device (Wakeup)

This device is battery operated and turned into deep sleep state most of the time to save battery life time. Communication with the device is limited. In order to communicate with the device, a static controller **C** is needed in the network. This controller will maintain a mailbox for the battery operated devices and store commands that can not be received during deep sleep state. Without such a controller, communication may become impossible and/or the battery life time is significantly decreased.

This device will wakeup regularly and announce the wakeup state by sending out a so called Wakeup Notification. The controller can then empty the mailbox. Therefore, the device needs to be configured with the desired wakeup interval and the node ID of the controller. If the device was included by a static controller this controller will usually perform all necessary configurations. The wakeup interval is a tradeoff between maximal battery life time and the desired responses of the device. To wakeup the device please perform the following action: When the device power on, the device will wake about 20 seconds. In this duration, the controller can communicate with the device. Normally the device is always sleeping to save the battery energy.

Quick trouble shooting

Here are a few hints for network installation if things dont work as expected.

1. Make sure a device is in factory reset state before including. In doubt exclude before include.
2. If inclusion still fails, check if both devices use the same frequency.
3. Remove all dead devices from associations. Otherwise you will see severe delays.
4. Never use sleeping battery devices without a central controller.
5. Dont poll FLIRS devices.
6. Make sure to have enough mains powered device to benefit from the meshing

Firmware-Update over the Air

This device is capable of receiving a new firmware 'over the air'. The update function needs to be supported by the central controller. Once the controller starts the update process, perform the following action to confirm the firmware update: The device support the Z-Wave firmware update via OTA. Let the controller into the firmware update mode, and then press the tamper key once to start the update. After finish the firmware download, the LED will start flash in every 0.5 second. At that time, please don't remove the battery , otherwise it will cause the firmware broken, and the device will no function. After the LED stop flash, it is recommended that the user power up the device. Caution: After remove the battery, please wait about 30 seconds, and then re-install the battery.

Association - one device controls an other device

Z-Wave devices control other Z-Wave devices. The relationship between one device controlling another device is called association. In order to control a different device, the controlling device needs to maintain a list of devices that will receive controlling commands. These lists are called association groups and they are always related to certain events (e.g. button pressed, sensor triggers, ...). In case the event happens all devices stored in the respective association group will receive the same wireless command wireless command, typically a 'Basic Set' Command.

Association Groups:

Group Number	Maximum Nodes	Description
1	8	The group 1 is for receiving the report message, like triggered event, temperature, humidity etc.
2	8	The group 2 is for the light control, the device will send the Basic Set command to this group. And each group support 8 nodes maximum.

Configuration Parameters

Z-Wave products are supposed to work out of the box after inclusion, however certain configuration can adapt the function better to user needs or unlock further enhanced features.

IMPORTANT: Controllers may only allow configuring signed values. In order to set values in the range 128 ... 255 the value sent in the application shall be the desired value minus 256. For example: To set a parameter to 200 it may be needed to set a value of 200 minus 256 = minus 56. In case of a two byte value the same logic applies: Values greater than 32768 may needed to be given as negative values too.

Parameter 5: Operation Mode

Operation mode. Using bit to control. Bit0: Disable the Flood function. Bit1: Reserve. Bit2: Reserve. Bit3: Setting the temperature scale. 0: Fahrenheit, 1: Celsius. Bit4: Reserve. Bit5: Disable the temperature report after event triggered. (1: Disable, 0: Enable). Bit6: Reserve. Bit7: Reserve.

Size: 1 Byte, Default Value: 0

Setting	Description
1	Disable the Flood function.
8	Setting the temperature scale. 0: Fahrenheit, 1: Celsius
32	Disable the temperature report after event triggered. (1: Disable, 0: Enable)

Parameter 7: Customer Function

Size: 1 Byte, Default Value: 0

Setting	Description
8	Disable send out BASIC OFF after the flood event cleared. (1: Disable, 0: Enable)
16	Notification Type, 0: Using Notification Report. 1: Using Sensor Binary Report.
32	Disable Multi CC in auto report. (1: Disable, 0: Enable)
64	Disable to report battery state when the device triggered. (1: Disable, 0: Enable)

Parameter 10: Auto Report Battery Time

The interval time for auto report the battery level. 0 means turn off auto report. The default value is 12. The tick time can setting by the configuration No.20.

Size: 1 Byte, Default Value: 18

Setting	Description
0 - 127	The interval time for auto report the battery level.

Parameter 13: Auto Report Temperature Time

The interval time for auto report the temperature. 0 means turn off auto report. The default value is 12. The tick time can setting by the configuration No.20.

Size: 1 Byte, Default Value: 18

Setting	Description
0 - 127	The interval time for auto report the temperature.

Parameter 14: Auto Report Humidity Time

The interval time for auto report the humidity. 0 means turn off auto report. The default value is 12. The tick time can setting by the configuration No.20.

Size: 1 Byte, Default Value: 18

Setting	Description
0 - 127	The interval time for auto report the humidity.

Parameter 20: Auto Report Tick Interval

The interval time for auto report each tick. Setting this configuration will effect configuration No.10, No.13, No.14 and No.15. Units of one minute. Caution1: Setting to 0 means turn off all auto report function. Caution2: The value is unsigned byte

Size: 1 Byte, Default Value: 30

Setting	Description
0 - 255	The interval time for auto report each tick.

Parameter 21: Temperature Differential Report

The temperature differential to report. 0 means turn off this function. The unit is Fahrenheit. Enable this function the device will detect every 10 seconds. And when

Setting	Description
0 - 127	The temperature differential to report. 0 means turn off this function.

Parameter 23: Humidity Differential Report

The humidity differential to report. 0 means turn off this function. The unit is percentage. Enable this function the device will detect every 10 seconds.

Size: 1 Byte, Default Value: 5

Setting	Description
0 - 60	The humidity differential to report.

Technical Data

Dimensions	0.0280000x0.0230000x0.0850000 mm
Weight	19.21 gr
Hardware Platform	SD3502
EAN	4251295701059
IP Class	IP 20
Battery Type	1 * CR123A
Device Type	Multilevel Sensor
Generic Device Class	Multilevel Sensor
Specific Device Class	Routing Multilevel Sensor
Network Operation	Reporting Sleeping Slave
Z-Wave Version	6.51.06
Certification ID	ZC10-15060010
Z-Wave Product Id	0x013C.0x0002.0x0020

Supported Command Classes

- Association
- Association Group Information
- Battery
- Sensor Binary
- Configuration
- Device Reset Locally
- Firmware Update Md
- Manufacturer Specific
- Multi Command
- Sensor Multilevel
- Notification
- Powerlevel
- Security
- Version
- Wake Up
- Zwaveplus Info

Controlled Command Classes

- Wake Up

Explanation of Z-Wave specific terms

- **Controller** — is a Z-Wave device with capabilities to manage the network. Controllers are typically Gateways, Remote Controls or battery operated wall

- **Primary Controller** — is the central organizer of the network. It must be a controller. There can be only one primary controller in a Z-Wave network.
- **Inclusion** — is the process of adding new Z-Wave devices into a network.
- **Exclusion** — is the process of removing Z-Wave devices from the network.
- **Association** — is a control relationship between a controlling device and a controlled device.
- **Wakeup Notification** — is a special wireless message issued by a Z-Wave device to announces that is able to communicate.
- **Node Information Frame** — is a special wireless message issued by a Z-Wave device to announce its capabilities and functions.