



Everspring

Indoor Voice Siren

SKU: EVRESE813



Quickstart

This is a **secure Siren for Europe**. To run this device please insert fresh **4 * LR14** batteries. Please make sure the internal battery is fully charged.

The voice siren supports Auto Inclusion feature where it will automatically enter Inclusion mode when first powered up after a factory reset.

Note: Depending on country, the unit may be shipped with batteries already inserted. In this case, simply pull out the Battery Mylar, set the Z-Wave controller into Inclusion mode and then proceed to step 4.

1. Carefully remove its back cover by peeling from the opening slot at the bottom.
2. Set the Z-Wave controller into Inclusion mode.
3. Insert the battery into the battery compartment. Note the correct polarity of battery as indicated.
4. The unit's LED will start to blink. The duration of Inclusion mode is 30 seconds.
5. The Inclusion process should be completed when the LED stops blinking.

Note: If you are connecting this unit to a Z-Wave Controller that utilizes the S2 security protocol, you may be asked by your controller to enter a 5-digit Device Specific Key (DSK) that is unique to each unit. This can be found in one of two places:

- on the QR code label on the back of the unit
- on the insert card inside the packaging.

Important safety information

Please read this manual carefully. Failure to follow the recommendations in this manual may be dangerous or may violate the law. The manufacturer, importer, distributor and seller shall not be liable for any loss or damage resulting from failure to comply with the instructions in this manual or any other material. Use this equipment only for its intended purpose. Follow the disposal instructions. Do not dispose of electronic equipment or batteries in a fire or near open heat sources.

What is Z-Wave?

Z-Wave is the international wireless protocol for communication in the Smart Home. This device is suited for use in the region mentioned in the Quickstart section.

Z-Wave ensures a reliable communication by reconfirming every message (**two-way communication**) and every mains powered node can act as a repeater for other nodes (**meshed network**) in case the receiver is not in direct wireless range of the transmitter.

This device and every other certified Z-Wave device can be **used together with any other certified Z-Wave device regardless of brand and origin** as long as both are suited for the same frequency range.

If a device supports **secure communication** it will communicate with other devices secure as long as this device provides the same or a higher level of security. Otherwise it will automatically turn into a lower level of security to maintain backward compatibility.

For more information about Z-Wave technology, devices, white papers etc. please refer to www.z-wave.info.



Product Description

The product is a voice alert and notification device. Pre-recorded voice sounds can be stored into its memory and played back through gateway commands. For example, when email arrives, the audio sound you've got mail can be heard from its speaker. It also has a separate piezoelectric siren to emit a deafening sound when activated under emergency. In addition, the built-in digital temperature sensor and humidity sensor reports environmental condition to the controller.

Prepare for Installation / Reset

Please read the user manual before installing the product.

In order to include (add) a Z-Wave device to a network it **must be in factory default state**. Please make sure to reset the device into factory default. You can do this by performing an Exclusion operation as described below in the manual. Every Z-Wave controller is able to perform this operation however it is recommended to use the primary controller of the previous network to make sure the very device is excluded properly from this network.

Reset to factory default

This device also allows to be reset without any involvement of a Z-Wave controller. This procedure should only be used when the primary controller is inoperable.

1. Press the Link button 3 times within 1.5 seconds to put the unit into exclusion mode.
2. Within 1 second of step 1, press the Link button again and hold for 5 seconds.
3. Node ID is excluded. The unit reverts to factory default state.

Safety Warning for Batteries

The product contains batteries. Please remove the batteries when the device is not used. Do not mix batteries of different charging level or different brands.

Installation

Inserting the batteries

1. Carefully remove its back cover by peeling from the opening slot at the bottom.
2. Insert the battery into the battery compartment. Note the correct polarity of battery as indicated.

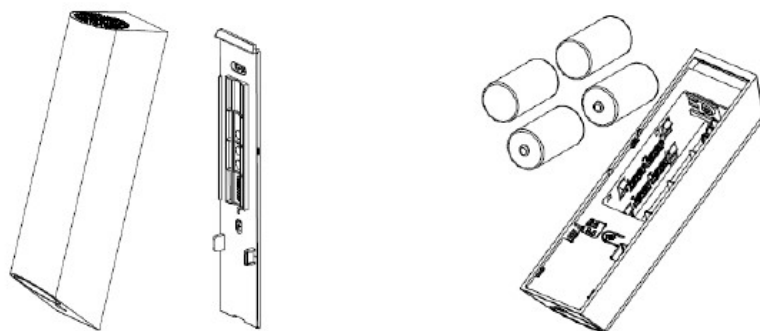

Mounting the Unit

The voice siren should be mounted in a vertical position about 2 meters from the floor.

1. Use the backplate as a template to mark and drill the position of two mounting holes on the wall. Fix the backplate to the wall using the plastic wall plugs and fixing screws provided.
2. Slide the unit down to its backplate and press against the wall to secure into place.

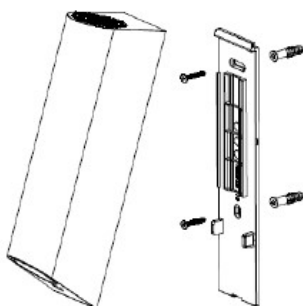

Inclusion/Exclusion

On factory default the device does not belong to any Z-Wave network. The device needs to be **added to an existing wireless network** to communicate with the devices of this network. This process is called **Inclusion**.

Devices can also be removed from a network. This process is called **Exclusion**. Both processes are initiated by the primary controller of the Z-Wave network. This controller is turned into exclusion respective inclusion mode. Inclusion and Exclusion is then performed doing a special manual action right on the device.

Inclusion

Press the Link button 3 times within 1.5 seconds to put the unit into inclusion mode.

Exclusion

Press the Link button 3 times within 1.5 seconds to put the unit into exclusion mode.

Product Usage

Product Overview

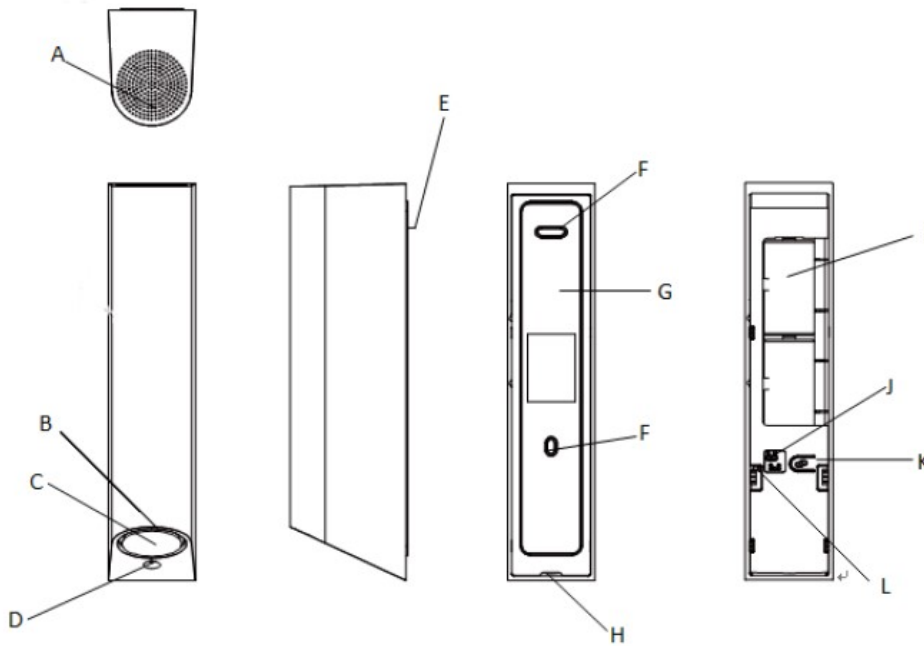

- A. Voice Speaker
- B. LED indicator
- C. Siren
- D. Temperature Sensor
- E. Battery Mylar
- F. Screw Mount
- G. Backplate
- H. Opening slot
- I. Battery
- J. Mini USB connector
- K. Link button
- L. Tamper switch

External Files:

For information on managing audio files on the siren, refer to the original manual included with the unit.

- Format : WAVE format (file extension .wav)
- Sample rate: 8KHz~32KHz.
- Mono only
- Maximum length : 30 seconds for each file

Note: MP3 file needs to be converted to .wav format.

1. Use a sound editor software on a PC to modify the audio files to fulfill the format above.
2. Save the files into a folder. Ensure the total size of all the files do not exceed 2MByte in size, which is roughly 85 seconds of playback.

Quick trouble shooting

Here are a few hints for network installation if things dont work as expected.

1. Make sure a device is in factory reset state before including. In doubt exclude before include.
2. If inclusion still fails, check if both devices use the same frequency.
3. Remove all dead devices from associations. Otherwise you will see severe delays.
4. Never use sleeping battery devices without a central controller.
5. Dont poll FLIRS devices.
6. Make sure to have enough mains powered device to benefit from the meshing

Association - one device controls an other device

Z-Wave devices control other Z-Wave devices. The relationship between one device controlling another device is called association. In order to control a different device, the controlling device needs to maintain a list of devices that will receive controlling commands. These lists are called association groups and they are always related to certain events (e.g. button pressed, sensor triggers, ...). In case the event happens all devices stored in the respective association group will receive the same wireless command wireless command, typically a 'Basic Set' Command.

Association Groups:

Group Number	Maximum Nodes	Description
1	5	Z-Wave Plus Lifeline

Configuration Parameters

IMPORTANT: Controllers may only allow configuring signed values. In order to set values in the range 128 ... 255 the value sent in the application shall be the desired value minus 256. For example: To set a parameter to 200 it may be needed to set a value of 200 minus 256 = minus 56. In case of a two byte value the same logic applies: Values greater than 32768 may needed to be given as negative values too.

Parameter 1: Siren alarm period

Siren alarm period

Size: 2 Byte, Default Value: 180

Setting	Description
10 - 600	Siren alarm period can be set 10~600 seconds.

Parameter 2: Temperature/Humidity Auto Report period setting

Temperature/ Humidity Auto Report period setting

Size: 2 Byte, Default Value: 30

Setting	Description
1 - 1440	Temperature/Humidity Auto Report period can be set 1~1440 minutes

Parameter 3: Sound Playback

Plays Sound

Size: 1 Byte, Default Value: 0

Setting	Description
0	Stop to play sound
1 - 99	memory location number

Technical Data

Dimensions	0.0450000x0.2000000x0.0590000 mm
Weight	172 gr
Hardware Platform	SD3502
EAN	4713616113588
IP Class	IP 20
Voltage	6V
Battery Type	4 * LR14
Device Type	Siren
Network Operation	Listening Sleeping Slave
Z-Wave Version	6.71.03
Certification ID	ZC10-18116293
Z-Wave Product Id	0x0060.0x000C.0x0003
Supported Notification Types	Siren
Color	White
Sensors	Air Temperature
Firmware Updatable	Updatable by Consumer by RF
Frequency	Europe - 868,4 Mhz
Maximum transmission power	5 mW

Supported Command Classes

- Association Grp Info
- Association V2
- Basic
- Battery
- Switch Binary

- Device Reset Locally
- Firmware Update Md V4
- Manufacturer Specific V2
- Notification V8
- Powerlevel
- Security 2
- Security
- Sensor Multilevel V5
- Sound Switch
- Supervision
- Transport Service V2
- Version V3
- Zwaveplus Info V2

Explanation of Z-Wave specific terms

- **Controller** — is a Z-Wave device with capabilities to manage the network. Controllers are typically Gateways, Remote Controls or battery operated wall controllers.
- **Slave** — is a Z-Wave device without capabilities to manage the network. Slaves can be sensors, actuators and even remote controls.
- **Primary Controller** — is the central organizer of the network. It must be a controller. There can be only one primary controller in a Z-Wave network.
- **Inclusion** — is the process of adding new Z-Wave devices into a network.
- **Exclusion** — is the process of removing Z-Wave devices from the network.
- **Association** — is a control relationship between a controlling device and a controlled device.
- **Wakeup Notification** — is a special wireless message issued by a Z-Wave device to announces that is able to communicate.
- **Node Information Frame** — is a special wireless message issued by a Z-Wave device to announce its capabilities and functions.