

Smart Switch 7

ZW175

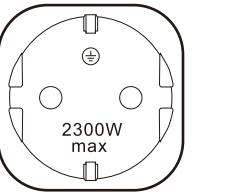

AEOTEC

Used in this guide.

Artículos utilizados en este manual / Utilisé dans ce guide / In dieser Gebrauchsanweisung verwendete Bezeichnungen / Usato in questa guida / Gebruikt in deze handleiding / Används i den här handboken / Brukt i denne håndboken.

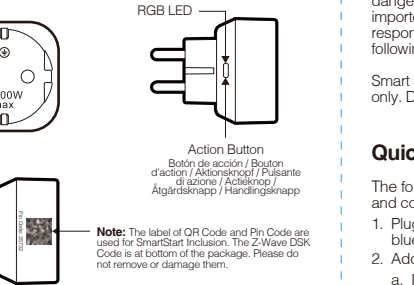

Important safety information.

Please read this and the online guide(s) at support.aeotec.com/ss7 carefully. Failure to follow the recommendations set forth by Aeotec Limited may be dangerous or cause a violation of the law. The manufacturer, importer, distributor, and / or reseller will not be held responsible for any loss or damage resulting from not following any instructions in this guide or in other materials.

Smart Switch 7 is intended for indoor use in dry locations only. Do not use in damp, moist, and / or wet locations.

Quick start.

The following will step you through installing Smart Switch 7 and connecting it to your Z-Wave network.

1. Plug Smart Switch 7 into a power outlet; its LED will flash blue slowly.
2. Add Smart Switch 7 to your Z-Wave network;
 - a. If your Z-Wave gateway supports SmartStart, Smart

Switch 7 is SmartStart enabled allowing you to connect it to your Z-Wave gateway by scanning your switch's QR Code using your gateway's app. Once scanned, Smart Switch 7 will join your Z-Wave network automatically within 10 minutes. Continue from step 3.

- b. Else, set your Z-Wave gateway into its 'add device' mode. Refer to the gateway's manual if you are unsure of how to perform this step.
- c. Tap Smart Switch 7's Action Button once, its blue LED will blink.
- d. If your gateway supports the Z-Wave Device Specific Key (DSK) security protocol, enter the first 5 digits of your switch's DSK into your gateway's interface when prompted.

3. When Smart Switch 7 successfully joins your Z-Wave network, its LED will become a solid blue colour for 2 seconds. Should its LED still flash blue, this indicates it was unable to join your Z-Wave network; repeat the above steps and please contact us for further support if needed.

Smart Switch 7 is now a part of your Z-Wave home control

system. You can configure it and its automations via your Z-Wave system; please refer to your software's user guide for precise instructions.

Get help & learn more.

Should you encounter any problem with Smart Switch 7, visit support.aeotec.com/ss7 or contact our support team via aeotec.com/contact. You can also learn more about Smart Switch 7 features, configuration options, and technical specifications at the link.

Gateway compatibility.

To see if this device is known to be compatible with your Z-Wave gateway, please refer to aeotec.com/z-wave-gateways.

Español.

Información importante de seguridad.

Por favor, lea cuidadosamente esta información y el manual en support.aeotec.com/ss7. No cumplir las recomendaciones establecidas por Aeotec Limited puede ser peligroso o constituir una violación a la ley. El fabricante, importador, distribuidor y / o revendedor no será considerado responsable por ninguna pérdida o daño que resulte de no cumplir cualquiera de las instrucciones contenidas en este manual o en otros materiales.

Smart Switch 7 está diseñado para su uso en espacios cerrados y secos. No utilizar en locaciones con condiciones de humedad y / o en espacios mojados.

Inicio rápido.

El siguiente manual le guiará en la instalación del Smart Switch 7 y su conexión a su red Z-Wave.

1. Conecte el Smart Switch 7 a una toma de corriente; su LED parpadeará en azul lentamente.
2. Agregue Smart Switch 7 a su red Z-Wave;
 - a. Si su puerta de enlace Z-Wave es compatible con SmartStart, Smart Switch 7 está habilitado para SmartStart, lo que le permite conectarlo a su puerta de enlace Z-Wave escaneando el código QR de su interruptor utilizando la aplicación de su puerta de enlace. Una vez escaneado, Smart Switch 7 se unirá a su red Z-Wave

Automáticamente en 10 minutos. Continuar desde el paso 3.

- b. De lo contrario, configure su puerta de enlace Z-Wave en su modo "agregar dispositivo". Consulte el manual de la puerta de enlace si no está seguro de cómo realizar este paso.
- c. Pulse el botón de acción del Smart Switch 7 una vez, su LED azul parpadeará.
- d. Si su puerta de enlace es compatible con el protocolo de seguridad de la clave específica del dispositivo (DSK) Z-Wave, ingrese los primeros 5 dígitos del DSK de su conmutador en la interfaz de su puerta de enlace cuando se le solicite.

3. Cuando Smart Switch 7 se une con éxito a su red Z-Wave, su LED se convertirá en un color azul sólido durante 2 segundos. Si su LED aún parpadea en azul, esto indica que no pudo unirse a su red Z-Wave; repita los pasos anteriores y póngase en contacto con nosotros para obtener más ayuda si es necesario.

El Smart Switch 7 ahora es parte de su sistema de control de hogar Z-Wave. Puede configurar tanto el dispositivo como las automatizaciones a través de su sistema Z-Wave; por favor, para obtener instrucciones más precisas revise el manual de usuario del Software.

Français.

Informations importantes concernant la sécurité

Veillez lire attentivement ce document et le(s) guide(s) à l'adresse support.aeotec.com/ss7. Le non-respect des recommandations formulées

par Aeotec Limited peut être dangereux ou entraîner une violation de la loi. Le fabricant, l'importateur, le distributeur et / ou le revendeur ne seront pas tenus responsables de toute perte ou dommage résultant du non-respect des instructions contenues dans ce guide ou dans d'autres documents.

Démarrage rapide.

Les étapes suivantes vous guideront dans l'installation de Smart Switch 7 et sa connexion à votre réseau Z-Wave.

1. Branchez la Smart Switch 7 dans une prise de courant; sa barre LED clignotera lentement en bleu.
2. Ajoutez la Smart Switch 7 à votre réseau Z-Wave ;
 - a. Si votre passerelle Z-Wave prend en charge SmartStart, Smart Switch 7 est activé par SmartStart, ce qui vous permet de le connecter à votre passerelle Z-Wave en scannant le code QR de votre commutateur à l'aide de son application. Une fois numérisé, Smart Switch 7 rejoindra automatiquement votre réseau Z-Wave dans les 10 minutes. Continuez à partir de l'étape 3.
 - b. Sinon, configurez votre passerelle Z-Wave en mode «Ajout de périphérique». Reportez-vous au manuel de la passerelle si vous ne savez pas comment effectuer cette étape.
 - c. Appuyez une fois sur le bouton d'action du commutateur intelligent 7, son voyant bleu clignotera.
 - d. Si votre passerelle prend en charge le protocole de sécurité Z-Wave

Deutsch.

Wichtige Sicherheitsinformationen.

Bitte lesen Sie dieses Dokument und die Anleitung(en) unter support.aeotec.com/ss7 sorgfältig durch. Den festgelegten Empfehlungen der Aeotec Limited nicht zu folgen, kann gefährlich sein oder gegen ein Gesetz verstoßen. Der Hersteller, Importeur, Vertreter und / oder Verkäufer haftet nicht für den Verlust oder Schaden, der durch die Nichtbeachtung der Vorschriften in dieser Anleitung oder in anderen Material entsteht.

Smart Switch 7 ist nur für den Innengebrauch bestimmt. Nicht in einer dunstigen, feuchten oder nassen Umgebung verwenden.

Schnellstart.

Im Folgenden werden Sie Schritt für Schritt durch die Installation und das Verbinden des Smart Switch 7 mit einem Z-Wave Netzwerk geführt.

1. Schließen Sie den Smart Switch 7 an eine Steckdose an; seine LED blinkt langsam blau.
2. Hinzufügen des Smart Switch 7 zu Ihrem Z-Wave Netzwerk;
 - a. Wenn Ihr Z-Wave-Gateway SmartStart unterstützt, ist Smart Switch 7 für SmartStart aktiviert, sodass Sie es mit Ihrem Z-Wave-Gateway verbinden können, indem Sie den QR-Code Ihres Switches mit der App Ihres Gateways scannen. Nach dem Scannen wird der Smart Switch 7 innerhalb von 10 Minuten automatisch mit Ihrem Z-Wave-Netzwerk verbunden. Fahren Sie mit Schritt 3 fort.
 - b. Anderenfalls setzen Sie Ihr Z-Wave Gateway in den Modus "Gerät hinzufügen". Lesen Sie im Handbuch des Gateways nach, wenn Sie nicht sicher sind, wie dieser Schritt ausgeführt werden soll.
 - c. Tippen Sie einmal auf die Aktionstaste des Smart Switch 7, die blaue LED blinkt.
 - d. Wenn Ihr Gateway das DSK-Protokoll (Device Specific Key) von Z-Wave unterstützt, geben Sie bei Aufforderung die ersten 5 Ziffern des DSK Ihres Switches in die Schnittstelle Ihres Gateways ein.
3. Wenn der Smart Switch 7 sich erfolgreich mit Ihrem Z-Wave Netzwerk verbindet, leuchtet seine LED für 2 Sekunden Blau. Wenn seine LED immer noch blau blinkt, ist die Verbindung mit Ihrem Z-Wave Netzwerk nicht zustande gekommen. Führen Sie dann das Hinzufügen des Sensors erneut durch. Für weitere Unterstützung kontaktieren Sie uns.

Der Smart Switch 7 ist jetzt eine Komponente Ihres Z-Wave Smart Home Systems. Sie können das Gerät und seine Automatisierungen nun über Ihre Z-Wave Zentrale konfigurieren. Nehmen Sie dazu bitte das Handbuch Ihrer Z-Wave Zentrale zur Hand und folgen Sie den Anweisungen für eine Automatisierung.

Italiano.

Informazioni importanti per la sicurezza.

Si prega di leggere attentamente il presente documento e la guida su support.aeotec.com/ss7. La mancata osservanza di queste raccomandazioni indicate da Aeotec Limited può essere pericoloso oppure violare le norme vigenti. Il produttore, importatore, distributore e / o rivenditore non saranno considerati responsabili per alcuna perdita o danno derivante dal mancato rispetto di qualsiasi istruzione contenuta nella presente guida o in altro materiale.

Smart Switch 7 è destinato esclusivamente a un uso interno in luoghi asciutti. Non utilizzare in luoghi bagnati o umidi.

Avvio rapido.

Quanto segue accompagnerà l'utente durante l'installazione di Smart Switch 7 e la relativa connessione alla rete Z-Wave.

- Inserire il dispositivo Smart Switch 7 in una presa elettrica; la barra LED lampeggerà brevemente in blu.
- Aggiungere il dispositivo Smart Switch 7 alla rete Z-Wave.
 - Se il gateway Z-Wave supporta SmartStart, Smart Switch 7 è abilitato per SmartStart e consente di collegarlo al gateway Z-Wave mediante la scansione del codice QR dello switch tramite l'app del gateway. Una volta scansionato, Smart Switch 7 si unirà automaticamente alla rete Z-Wave entro 10 minuti. Continua dal passaggio 3.
 - Altrimenti, impostare il gateway Z-Wave nella modalità 'Aggiungi

dispositivo'. Fare riferimento al manuale del gateway se non si è sicuri di come eseguire questo passaggio.

- Tocca il pulsante Azione di Smart Switch 7 una volta, il suo LED blu lampeggia.
- Se il gateway supporta il protocollo di sicurezza della chiave specifica del dispositivo Z-Wave (DSK), inserire le prime 5 cifre del DSK dello switch nell'interfaccia del gateway quando richiesto.
- Una volta che il dispositivo Smart Switch 7 sarà collegato con successo alla rete Z-Wave, il suo LED si illuminerà di blu per 2 secondi. Nel caso il LED continui a lampeggiare in blu, il dispositivo non è stato in grado di collegarsi alla rete di Z-Wave; ripetere i passaggi precedenti e contattare il nostro servizio clienti in caso sia necessario ulteriore supporto.

A questo punto Smart Switch 7 è parte del sistema di controllo domestico di Z-Wave. È possibile configurarlo e automatizzarlo attraverso il sistema Z-Wave; per istruzioni precise, consultare la guida utente del software.

Nederlands.

Belangrijke veiligheidsinformatie.

Lees dit en de handleiding(en) op support.aeotec.com/ss7 zorgvuldig door. Het niet opvolgen van de aanbevelingen uiteengezet door Aeotec Limited kan gevaarlijk zijn of een overtreding van de wet veroorzaken. De fabrikant, importeur, distributeur en / of verkoper kunnen niet aansprakelijk worden gesteld voor verlies of schade als gevolg van het niet opvolgen van instructies in deze handleiding of in andere documenten.

Smart Switch 7 is alleen bedoeld voor gebruik binnenshuis, op droge locaties. Niet gebruiken op vochtige, klamme en / of natte locaties.

Snelstart.

Hieronder volgt een beschrijving van de installatie van Smart Switch 7 en de verbinding met uw Z-Wave-netwerk.

- Sluit de Slimme schakelaar 6 aan op een stopcontact; de LED zal langzaam blauw knipperen.
- Voeg de Smart Switch 7 toe aan uw Z-Wave netwerk;
 - Als uw Z-Wave gateway SmartStart ondersteunt, is Smart Switch 7 uitgerust met SmartStart, zodat u deze kunt verbinden met uw Z-Wave gateway door de QR-code van uw switch te scannen met behulp van de app van uw gateway. Eenmaal gescand, wordt Smart Switch 7 binnen 10 minuten automatisch lid van uw Z-Wave-netwerk. Ga verder vanaf stap 3.
 - Anders, zet uw Z-Wave-gateway in de modus 'apparaat toevoegen'. Raadpleeg de handleiding van de gateway als u niet zeker weet hoe u deze stap moet uitvoeren.
 - Tik eenmaal op de actieknop van Smart Switch 7, de blauwe LED knippert.
 - Als uw gateway het beveiligingsprotocol van de Z-Wave Device Specific Key (DSK) ondersteunt, voert u de eerste 5 cijfers van de DSK van uw switch in de interface van uw gateway in wanneer daarom wordt gevraagd.
- Wanneer de Smart Switch 7 succesvol verbinding maakt met uw Z-Wave netwerk, zal de LED gedurende 2 seconden blauw blijven branden. Mocht de LED toch blauw blijven knipperen, dan is dit een indicatie dat

het niet is gelukt om verbinding te maken met uw Z-Wave netwerk; herhaal de bovenstaande stappen en neem contact op met ons voor verdere hulp indien nodig.

Smart Switch 7 is nu onderdeel van uw Z-Wave thuis beheersysteem. U kunt het configureren en automatiseren via uw Z-Wave-systeem. Raadpleeg de gebruikershandleiding van uw software voor instructies.

Svenska.

Viktig säkerhetsinformation.

Vänligen läs denna och guiderna på support.aeotec.com/ss7 noggrant. Underlåtenhet att följa rekommendationerna från Aeotec Limited kan vara farligt eller leda till brott mot lagen. Tillverkaren, importören, distributören, och / eller återförsäljaren kan inte hållas ansvariga för förlust eller skada som uppstår från att inte följa instruktionerna i denna handbok eller i andra material.

Smart Switch 7 är endast avsedd för inomhusbruk på torra platser. Använd inte i blöta, fuktiga och / eller våta miljöer.

Snabbstart.

Följande kommer att vägleda dig genom installationen av Smart Switch 7 och anslutning till ditt Z-Wave-nätverk.

- Anslut Smart Switch 7 till ett vägguttag; dess LED-streck kommer att blinka blått sakta.

2. Lägg till Smart Switch 7 i ditt Z-Wave-nätverk:

- Om din Z-Wave-gateway stöder SmartStart, är Smart Switch 7 SmartStart-aktiverad så att du kan ansluta den till din Z-Wave-gateway genom att skanna din växlär QR-kod med hjälp av din gateways app. När du har skannat, kommer Smart Switch 7 automatiskt att ansluta till ditt Z-Wave-nätverk inom 10 minuter. Fortsätt från steg 3.
 - Annars, sätt din Z-Wave-gateway i sitt "add device" -läge. Se gatewayens manual om du är osäker på hur du utför detta steg.
 - Tryck en gång på Smart Switch 7s Action Button, den blå LED-lampan blinkar.
 - Om din gateway stöder säkerhetsprotokollet Z-Wave Device Specific Key (DSK) anger du de första 5 siffrorna i din växels DSK i portens gränssnitt när du blir ombedd.
3. När Smart Switch 7 lyckas gå med i ditt Z-Wave network kommer dess LED lysa blått i 2 sekunder. Om dess LED skulle återgå till att blinka blått har den inte lyckats gå med i ditt Z-Wave-nätverk; repetera stegen ovan och kontakta oss gärna för support om det behövs.

Smart Switch 7 är nu en del av ditt Z-Wave hemkontrollsystem. Du kan konfigurera den och dess automationer via ditt Z-Wave-system; Se programvarans bruksanvisning för exakta instruktioner.

Declaration of Conformity. Aeotec Limited declares that ZW175 is in compliance with the essential requirements and other relevant provisions of RED 2014/53/EU, RoHS 2011/65/EU, IEC 62321:2008, EN 50581:2012 and

ErP Directive 2009/125/EC, No 1275/2008 AMENDMENT 801/2013. The full text of the declaration is available from support.aeotec.com/ss7/doc

Specifications. Z-Wave devices operate between 868.40 & 926.3 MHz depending on local restrictions. Full information on device specifications and certifications at support.aeotec.com/ss7/specs

Declaración de conformidad. Aeotec Limited declara que el ZW175 está en cumplimiento con los requerimientos esenciales y otras provisiones relevantes de RED 2014/53/EU, RoHS 2011/65/EU, IEC 62321:2008, EN 50581:2012 y las Directrices ErP 2009/125/EC, Nro.1275/2008 ENMIENDA 801/2013. El texto completo de esta declaración está disponible en support.aeotec.com/ss7/doc

Especificaciones. Los dispositivos Z-Wave operan entre 868,40 y 926,3 MHz dependiendo de las restricciones locales. Puede encontrar la información completa sobre las especificaciones y certificaciones del dispositivo en support.aeotec.com/ss7/specs

Déclaration de conformité. Aeotec Limited déclare que le ZW175 est conforme aux exigences essentielles et autres dispositions pertinentes de RED 2014/53/EU, RoHS 2011/65/EU, IEC 62321:2008, EN 50581:2012 e della Direttiva ErP 2009/125/EC, No 1275/2008 EMENDAMENTO 801/2013. Il testo complete della dichiarazione è disponibile su support.aeotec.com/ss7/doc

Spécifications. Les appareils Z-Wave fonctionnent entre 868,40 et 926,3 MHz selon les restrictions locales. Informations complètes sur les spécifications et certifications des appareils sur support.aeotec.com/ss7/specs

Konformitätserklärung. Aeotec Limited erklärt, dass das ZW175 den grundlegenden Anforderungen und anderen relevanten Bestimmungen von RED 2014/53 / EU, RoHS 2011/65 / EU, IEC 62321: 2008, EN 50581: 2012 und ErP-Richtlinie 2009/125 entspricht / EG, Nr. 1275/2008 ÄNDERUNGSANTRAG 801/2013. Der vollständige Wortlaut der Erklärung ist unter folgender Internetadresse support.aeotec.com/ss7/doc abrufbar.

Spezifikationen. Z-Wave Geräte arbeiten zwischen 868.40 und 926.3 Mhz in Abhängigkeit von lokalen Beschränkungen. Vollständige Informationen über Gerätespezifikationen und Zertifizierungen finden Sie auf support.aeotec.com/ss7/specs

Dichiarazione di conformità. Aeotec Limited dichiara che ZW175 è conforme ai requisiti fondamentali e altre disposizioni importanti di RED 2014/53/EU, RoHS 2011/65/EU, IEC 62321:2008, EN 50581:2012 e della Direttiva ErP 2009/125/EC, No 1275/2008 EMENDAMENTO 801/2013. Il testo complete della dichiarazione è disponibile su support.aeotec.com/ss7/doc

Specifiche tecniche. I dispositivi Z-Wave operano tra 868.40 e 926.3 MHz in base alle restrizioni locali. Informazioni complete sulle specifiche del dispositivo e sulle certificazioni su support.aeotec.com/ss7/specs

Conformiteitsverklaring. Aeotec Limited verklaart dat ZW175 voldoet aan alle essentiële vereisten en andere bepalingen van de Richtlijn radioapparatuur 2014/53/EU, Richtlijn 2011/65/EU, IEC 62321:2008, EN 50581:2012, en Verordening (EU) nr. 874/2012. De volledige tekst van de verklaring is beschikbaar vanaf support.aeotec.com/ss7/doc

Specificaties. Z-Wave-apparaten functioneren tussen 868,40 en 926,3 MHz,

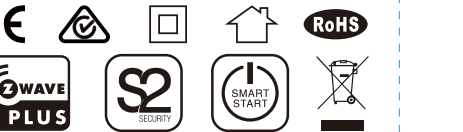

FCC ID: 2AOGIZW175

In Europe contact Aeotec Group GmbH; Große Johannisstraße 7, 20457 Hamburg, Germany.

© & ™ Aeotec Limited. Version: FT501017500001 - AA



✉ service@aeotec.com

@ www.aeotec.com

Aeotec

Smart Switch 7



Engineering Specification

Smart Switch 7

Document No.	SPEC-ZW175-C16
Description	<p>This document mainly introduces the new generation AEOTEC Smart Switch. The content mainly includes its interfaces, accessories, features, specifications, quick start, and software function definition.</p> <p>Smart Switch 7 is based on Z-Wave with many advantages.</p> <ul style="list-style-type: none">● Elegant appearance, small size, easy to use, friendly operation● Support wireless control with Z-Wave command or manually control with Action Button to change switch state● Support power metering function, with high measurement accuracy, and more accurate knowledge of the power consumption of the load● Support over-current, over-load and over-heat protection, which is more secure and reliable● Support scene personalization and is more intelligent● Support Night Light Mode to reduce light pollution● Support S2 Security, which is safer and more reliable● Support SmartStart, making inclusion more convenient
Written By	
Date	
Reviewed By	
Date	
Approved By	
Date	

Table of Content

1	INTERFACES & ACCESSORIES	1
2	FEATURES & SPECIFICATIONS	2
3	PRODUCT QUICK START.....	3
3.1	<i>Important safety information</i>	3
3.2	<i>How to install the product</i>	3
3.3	<i>How to add the product into Z-Wave network.....</i>	3
3.3.1	SmartStart Learn Mode	3
3.3.2	Classic Inclusion Learn Mode	3
3.4	<i>How to remove the product from Z-Wave network</i>	4
3.5	<i>How to factory reset</i>	4
4	SOFTWARE FUNCTION DEFINITION	5
4.1	<i>User Behavior Interaction</i>	5
4.2	<i>Supported Command Classes.....</i>	6
4.3	<i>Basic Command Class mapping</i>	7
4.4	<i>Z-Wave Plus Info</i>	7
4.5	<i>Manufacturer Specific.....</i>	7
4.6	<i>Version</i>	8
4.7	<i>Notification</i>	8
4.8	<i>Protection</i>	8
4.8.1	Protection Supported Report	8
4.8.2	Protection Set	8
4.9	<i>Association Group Info.....</i>	10
4.10	<i>Configuration</i>	10

1 INTERFACES & ACCESSORIES

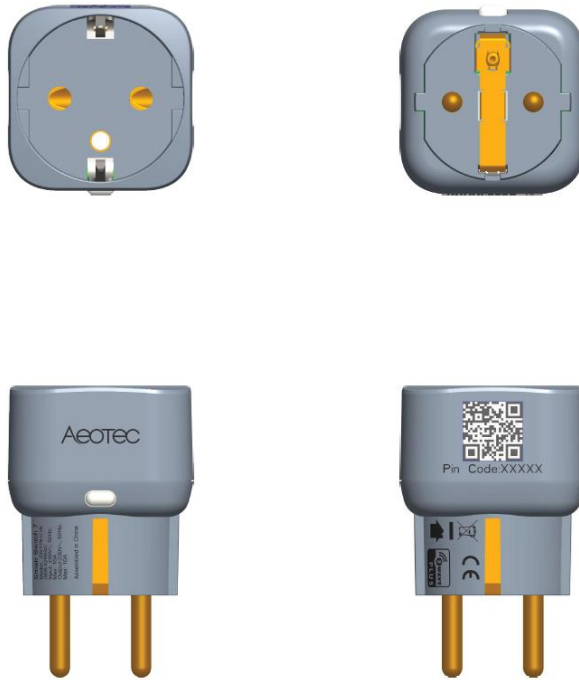

Terminology	Description
Action Button	Used for networking and resetting.
Indicator Light	Used for indicating the current state of the product.

2 FEATURES & SPECIFICATIONS

Parameter	Value
Product Identifier	ZW175-C16
Dimensions	43.4*43.4*68mm
Weight	56g
Color	White
Shell Material	PC-110N
Shell Surface Treatment	Mirror(upper shell), Bright fine lines(lower shell)
Shell Fire-proof Level	UL94 V-0
Waterproof and Dustproof	Rated IP20 under IEC 60529
Usage	For indoor use
Operating Temperature	32~104°F (0~40°C)
Relative Humidity	8%~80%
Wireless Technology	Z-Wave
Z-Wave Plus	Yes
Z-Wave Module	ZM5101
Z-Wave Version	6.81.03
Z-Wave Library Type	Enhanced 232 Slave
Z-Wave Device Type	On/Off Power Switch
Z-Wave Role Type	Always On Slave
Security Class	Non-Security, S0, S2 Unauthenticated, and S2 Authenticated
Smart Start Compatible	Support
Over The Air (OTA)	Support
Multi Channel Device	No
Association	Support
Factory Reset	Support
Power-down Memory	Support
Z-Wave Antenna Distance	30m (Indoor) /150m (Outdoor)
Plug and Socket Type	Plug Type E/F, Socket Type F
Indicator Light Color	RGB
Buttons and Connectors	Action Button (x1)
Input Voltage	230VAC, 50Hz
Battery Included	No
Battery Required	No
Working Current	7mA±5%(R.M.S) when switch is ON
Standby Current	4mA±5%(R.M.S) when switch is OFF
Maximum Output Current	10A(Resistive load)
Maximum Output Power	2300W
Maximum Standby Power Consumption	0.8W
Meter Type and Scale	Type=Electric Meter; Scale=kWh(Power Consumption), W(Power), V(Voltage), A(Current)
Power Meter Accuracy	±3W(Less than 300W), ±1%(Over 300W)
Over-Current Protection	Support. Automatically disconnects the load when the current is over 11A.
Over-Load Protection	Support. Automatically disconnects the load when the power is over the threshold value.
Over-Heat Protection	Support. Built-in unrecoverable temperature fuse. Automatically disconnects the load when the internal temperature exceeds the limit.
Switch Control Method	Wireless control with Z-Wave command or manually control with Action Button.
Night Light Mode	Support. Brightness and color can be customized by user.
Built-in Sensors	No built-in sensors
Safety Certifications	EU: CE

3 PRODUCT QUICK START

3.1 Important safety information

Please read this Engineering Specification carefully for correct and effective use.

Failure to follow the recommendations set forth by AEOTEC Limited may be dangerous or cause a violation of the law. The manufacturer, importer, distributor, and/or reseller will not be held responsible for any loss or damage resulting from not following any instruction in this guide or in other materials.

3.2 How to install the product

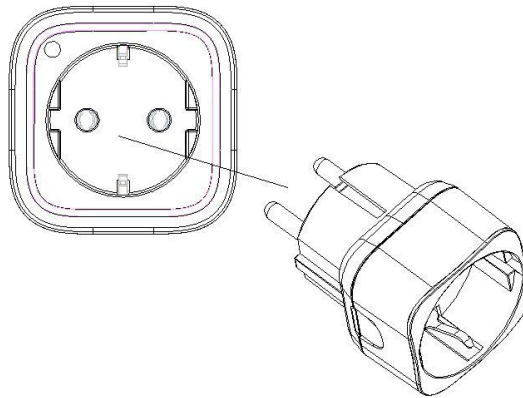

3.3 How to add the product into Z-Wave network

This product supports Security 2 Command Class. While a Security S2 enabled Controller is needed in order to fully use the security feature. This product can be included and operated in any Z-Wave network with other Z-Wave certified devices from other manufacturers and/or other applications. All non-battery operated nodes within the network will act as repeaters regardless of vendor to increase reliability of the network.

3.3.1 SmartStart Learn Mode

SmartStart enabled products can be added into a Z-Wave network by scanning the Z-Wave QR Code present on the product with a controller providing SmartStart inclusion. No further action is required and the SmartStart product will be added automatically within 10 minutes of being switched on in the network vicinity.

Indicator Light will become flash white light for 1s indicating the product has been powered, and then become flash blue light indicating SmartStart Learn Mode starts. It will become constantly bright yellow light after being assigned a NodeID.

If Adding succeeds, it will bright blue light for 2s and become Load Indicator Mode.

If Adding fails, it will bright red light for 2s and turn back to breathing blue light and then start SmartStart Learn Mode again.

Note:

The label of QR Code on the product and package are used for SmartStart Inclusion. The Z-Wave DSK Code is at bottom of the package. Please do not remove or damage them.

3.3.2 Classic Inclusion Learn Mode

1. Set your Z-Wave Controller into its 'Add Device' mode in order to add the product into your Z-Wave system. Refer to the Controller's manual if you are unsure of how to perform this step.

2. Make sure the product is powered. If not, plug it into a wall socket and power on; its LED will be breathing blue light all the time.
3. Click Action Button once, it will quickly flash blue light for 30 seconds until it is added into the network. It will become constantly bright yellow light after being assigned a NodeID.
4. If your Z-Wave Controller supports S2 encryption, enter the first 5 digits of DSK into your Controller's interface if /when requested. The DSK is printed on its housing.
5. If Adding fails, it will bright red light for 2s and then become breathing blue light; repeat steps 1 to 4. Contact us for further support if needed.
6. If Adding succeeds, it will bright blue light for 2s and then turn to Load Indicator Mode. Now, this product is a part of your Z-Wave home control system. You can configure it and its automations via your Z-Wave system; please refer to your software's user guide for precise instructions.

Note:

If Action Button is clicked again during the Classic Inclusion Learn Mode, the Classic Inclusion Learn Mode will exit. At the same time, Indicator Light will bright red light for 2s, and then become breathing blue light.

3.4 How to remove the product from Z-Wave network

1. Set your Z-Wave Controller into its 'Remove Device' mode in order to remove the product from your Z-Wave system. Refer to the Controller's manual if you are unsure of how to perform this step.
2. Make sure the product is powered. If not, plug it into a wall socket and power on.
3. Click Action Button 2 times quickly; it will bright violet light, up to 2s.
4. If Removing fails, it will bright red light for 2s and then turn back to Load Indicator Mode; repeat steps 1 to 3. Contact us for further support if needed.
5. If Removing succeeds, it will become breathing blue light. Now, it is removed from Z-Wave network successfully.

3.5 How to factory reset

If the primary controller is missing or inoperable, you may need to reset the device to factory settings.

Make sure the product is powered. If not, plug it into a wall socket and power on. To complete the reset process manually, press and hold the Action Button for at least 15s and then release. The LED indicator will become breathing blue light, which indicates the reset operation is successful. Otherwise, please try again. Contact us for further support if needed.

Note:

1. This procedure should only be used when the primary controller is missing or inoperable.
2. Factory Reset will:
 - (a) Remove the product from Z-Wave network;
 - (b) Delete the Association setting;
 - (c) Restore the configuration settings to the default.

4 SOFTWARE FUNCTION DEFINITION

4.1 User Behavior Interaction

Note: Please refer to Configuration Parameter 0x51 for more details about Load Indicator Mode in the below table.

User behavior	Out of the Z-Wave network	In the Z-Wave network
Power OFF	Cut the power.	Cut the power.
Power ON	<p>SmartStart Learn Mode: Indicator Light will become flash white light for 1s indicating the product has been powered, and then become flash blue light indicating SmartStart Learn Mode starts. It will become constantly bright yellow light after being assigned a NodeID.</p> <p>If Adding succeeds, it will bright blue light for 2s and become Load Indicator Mode.</p> <p>If Adding fails, it will bright red light for 2s and turn back to breathing blue light and then start SmartStart Learn Mode again.</p>	<p>Supply power: Indicator Light will become flash white light for 1s indicating the product has been powered, and then become Load Indicator Mode.</p>
Click Action Button once	<p>1.Send Node Info for Adding: When click Action Button once, Indicator Light will quickly flash blue light for 30s until it is added into the network. It will become constantly bright yellow light after being assigned a NodeID.</p> <p>If Adding succeeds, it will bright blue light for 2s and become Load Indicator Mode.</p> <p>If Adding fails, it will bright red light for 2s and then become breathing blue light.</p> <p>2.Exit Classic Inclusion Learn Mode: If Action Button is clicked again during the Classic Inclusion Learn Mode, the Learn Mode will exit. At the same time, Indicator Light will extinguish immediately, and then become breathing blue light.</p>	<p>1.Toggle the switch state: Indicator Light is closely related to the configuration of Load Indicator Mode.</p> <p>2.Exit testing communication quality: If the product is triggered to testing communication quality, it will exit when click the Action Button once, and Indicator Light will display the color according to the communication quality, and then turn back to Load Indicator Mode.</p>
Click Action Button 2 times quickly	<p>Reserved: Indicator Light will become off when press, and become breathing blue light when release.</p>	<p>Send Node Info for Removing: Indicator Light will become violet light for up to 2s.</p> <p>If Removing succeeds, it will become breathing blue light.</p> <p>If Removing fails, it will bright red light for 2s and then turn back to Load Indicator Mode.</p>
Click Action Button 3 times quickly	<p>Reserved: Indicator Light will become off when press, and become breathing blue light when release.</p>	<p>Disable the Alarm Response: This function is related to the setting of Configuration Parameter 10. If Parameter 10 is set to be 0, then when an enable alarm is received, user can disable the alarm response by 3x tapping Action Button within 1 second.</p>
Press and hold Action Button for [1, 2s)	<p>Reserved: Indicator Light will become off when press, and become breathing blue light when release.</p>	<p>Reserved: Indicator Light will become off when press, and become breathing blue light when release.</p>

<p>Press and hold Action Button for [2, 5s)</p>	<p>Reserved: Indicator Light will become orange light when press, and become breathing blue light when release.</p>	<p>Change Load Indicator Mode between Disable Mode and ON/OFF Mode: Indicator Light will become orange light when press. And when release, it will change the Light Indicator Mode from other mode to Disable Mode, or from Disable Mode to ON/OFF Mode.</p>
<p>Press and hold Action Button for [5, 10s)</p>	<p>Reserved: Indicator Light will become cyan light when press, and become breathing blue light when release.</p>	<p>Test communication quality: Indicator Light will become cyan light when press, and quickly flash cyan light when release, indicating start to test communication quality between the product and Node 1. At the end of the test, Indicator Light will display the color according to the communication quality. If the communication quality is Good, it will bright green light for 2s. If the communication quality is General, it will bright yellow light for 2s. If the communication quality is Poor, it will bright red light for 2s.</p>
<p>Press and hold Action Button for [10, 15s)</p>	<p>Reserved: Indicator Light will become speedup flashing red light when press, and become breathing blue light when release.</p>	<p>Reserved: Indicator Light will become flash red light when press, and become Load Indicator Mode when release.</p>
<p>Press and hold Action Button for [15, 20s)</p>	<p>Reserved: Indicator Light will become speedup flashing red light when press, and become breathing blue light when release.</p>	<p>Factory Reset(when release) Indicator Light will become speedup flashing red light when press, Factory Reset is performed when release. The product will send out Device Reset Locally Notification Report via Lifeline, and it will perform factory reset no matter the Nodes in the Lifeline Group receive the Device Reset Locally Notification from it or not. Indicator Light will become breathing blue light, which indicates the reset operation is successful.</p>
<p>Press and hold Action Button for [20, ∞)</p>	<p>Reserved: When the time reaches 20s, Indicator Light will become breathing blue light, no matter it is pressed or released.</p>	<p>Factory Reset(forced) When the time reaches 20s, Factory Reset is performed no matter Action Button is pressed or released. The product will send out Device Reset Locally Notification Report via Lifeline, and it will perform factory reset no matter the Nodes in the Lifeline Group receive the Device Reset Locally Notification from it or not. Indicator Light will become breathing blue light, which indicates the reset operation is successful.</p>

4.2 Supported Command Classes

Note:

When DUT is included on S0 level, MANUFACTURER_SPECIFIC CC is supported non-securely.

When DUT is included on S2 level, MANUFACTURER_SPECIFIC CC is supported securely only.

Command Class	Version	Not added	Non-secure added	Securely 0 added		Securely 2 added	
				Non-secure	Secure	Non-secure	Secure
ZWAVEPLUS_INFO	2	Support	Support	Support		Support	
ASSOCIATION	2	Support	Support		Support		Support
ASSOCIATION_GRP_INFO	1	Support	Support		Support		Support
TRANSPORT_SERVICE	2	Support	Support	Support		Support	
CONFIGURATION	1	Support	Support		Support		Support
SWITCH_BINARY	1	Support	Support		Support		Support
METER	4	Support	Support		Support		Support
CLOCK	1	Support	Support		Support		Support
SWITCH_COLOR	1	Support	Support		Support		Support
SWITCH_MULTILEVEL	2	Support	Support		Support		Support
NOTIFICATION	4	Support	Support		Support		Support
PROTECTION	2	Support	Support		Support		Support
SCENE_ACTUATOR_CONF	1	Support	Support		Support		Support
SCENE_ACTIVATION	1	Support	Support		Support		Support
VERSION	2	Support	Support		Support		Support
MANUFACTURER_SPECIFIC	2	Support	Support	Support			Support
DEVICE_RESET_LOCALLY	1	Support	Support		Support		Support
POWERLEVEL	1	Support	Support		Support		Support
SECURITY	1	Support	Support	Support		Support	
SECURITY_2	1	Support	Support	Support		Support	
SUPERVISION	1	Support	Support	Support		Support	
APPLICATION_STATUS	1	Support	Support	Support		Support	
FIRMWARE_UPDATE_MD	4	Support	Support		Support		Support

4.3 Basic Command Class mapping

Basic Set maps to Binary Switch Set.

Basic Get maps to Binary Switch Get

Basic Report maps to Binary Switch Report.

4.4 Z-Wave Plus Info

Parameter	Value
Z-Wave Plus Version	1
Role Type	5 (ZWAVEPLUS_INFO_REPORT_ROLE_TYPE_SLAVE_ALWAYS_ON)
Node Type	0 (ZWAVEPLUS_INFO_REPORT_NODE_TYPE_ZWAVEPLUS_NODE)
Installer Icon Type	0x0700 (ICON_TYPE_GENERIC_ON_OFF_POWER_SWITCH)
User Icon Type	0x0700 (ICON_TYPE_GENERIC_ON_OFF_POWER_SWITCH)

4.5 Manufacturer Specific

Parameter	Value
Manufacturer ID 1	0x03
Manufacturer ID 2	0x71
Product Type ID 1	0x00(EU)
Product Type ID 2	0x03
Product ID 1	0x00
Product ID 2	0xAF

4.6 Version

Parameter	Value
Z-Wave Protocol Library Type	0x03
Z-Wave Protocol Version	0x06
Z-Wave Protocol Sub Version	0x04
Firmware 0 Version	ZM5101 Software Version MSB
Firmware 0 Sub Version	ZM5101 Software Version LSB
Hardware Version	0xAF
Number of firmware targets	0x00

4.7 Notification

Notification Type		Notification Events		Description
Power Management	0x08	State idle	0x00	Idle
		Over-current detected	0x06	Current is over 11A.
		Over-load detected	0x08	Power is over the threshold value.
System	0x09	State idle	0x00	N/A
		System hardware failure (manufacturer proprietary failure code provided)	0x03	Event/State Parameter=0x01: Built-in unrecoverable temperature fuse has detected the internal temperature exceeds the limit and disconnect. It also means that the product has damaged if this notification is sent out.

4.8 Protection

4.8.1 Protection Supported Report

Parameter	Value
Local Protection State Byte 1	0x05
Local Protection State Byte 2	0x00
RF Protection State Byte 1	0x03
RF Protection State Byte 2	0x00
Exclusive Control	0x00
Timeout	0x00

4.8.2 Protection Set

Parameter	Value	Function
Local Protection State Byte	0	Unprotected. The device is not protected, and may be operated normally via the user interface.
	2	No operation possible. It is not possible at all to control a device directly via the user interface.
RF Protection State Byte	0	Unprotected. The device MUST accept and respond to all RF Commands.
	1	No RF control - all runtime Commands are ignored by the device. The device MUST still respond with status on requests.

Note:

(1) Regardless of the state of the product, when over-current or over-load detected, it will automatically TURN OFF switch and set Local Protection State to be 2 and RF Protection State to be 1, and start red light blinking. Users can't manually or RF control the switch state until setting the Protection State to be unprotected through the Gateway or Controller, even power off will still keep Protection State.

(2) Different protection trigger

Protection trigger	Activation condition	Result	How to cancel/disable
Local Protection	Protection Set: Local Protection State = 2	No operation possible. It is not possible at all to control a device directly via the user interface.	Protection Set: Local Protection State = 0
RF Protection	Protection Set: RF Protection State = 1	No RF control - all runtime Commands are ignored by the device.	Protection Set: RF Protection State = 0
Alarm Report	Receive any alarm enabled by Alarm Settings (Parameter 9)	(1)Switch will react based on Alarm Response (Parameter 8), and Indicator Light will keep blinking based on Parameter 18. (2)Local Protection State will NOT automatically change to be 2. However, it is not possible at all to control a device directly via the user interface until alarm is disable. (3)RF Protection State will NOT automatically change to be 1. However, Switch will report Application Rejected Request when receives any command which can control the switch state until alarm is disable.	Based on the setting to disable alarm (Parameter 10). Note: Power off will also disable the alarm response without any limitation.
Over-current detected	The current of the load connected is over 11A.	(1)Blinking red light. (2)Turn off switch. (3)Local Protection State will automatically change to be 2. It is not possible at all to control a device directly via the user interface until users set the Local Protection State to be 0(unprotected). (4)RF Protection State will automatically change to be 1. Switch will report Application Rejected Request when receives any command which can control the switch state until users set the RF Protection State to be 0(unprotected).	Protection Set: Local Protection State = 0 RF Protection State = 0
Over-load detected	The power of the load connected is over the threshold value.(Parameter 4)	(1)Blinking red light. (2)Turn off switch. (3)Local Protection State will automatically change to be 2. It is not possible at all to control a device directly via the user interface until users set the Local Protection State to be 0(unprotected). (4)RF Protection State will automatically change to be 1. Switch will report Application Rejected Request when receives any command which can control the switch state until users set the RF Protection State to be 0(unprotected).	Protection Set: Local Protection State = 0 RF Protection State = 0

4.9 Association Group Info

Root device

ID	Name	Node count	Profile	Function
1	Lifeline	5	General: Lifeline	<p>Device Reset Locally Notification: Issued when Factory Reset is performed.</p> <p>Basic Report: Issued when switch state has changed.</p> <p>Binary Switch Report: Issued when switch state has changed.</p> <p>Color Switch Report: Issued when a color component level of the Indicator Light has changed.</p> <p>Multilevel Switch Report: Issued when the multilevel switch value of the Indicator Light has changed.</p> <p>Notification Report (Type=0x08; Event=0x06): Issued when over-current detected.</p> <p>Notification Report (Type=0x08; Event=0x08): Issued when over-load detected.</p> <p>Notification Report (Type=0x08; Event=0x00): Issued when over-current or over-load is release.</p> <p>Notification Report (Type=0x09; Event=0x03): Issued when built-in unrecoverable temperature fuse detected the internal temperature exceeds the limit and disconnect.</p> <p>Meter Report: Issued periodically to report the current Meter reading, and the sending frequency is related to Configuration Parameter 0x6F (111). Issued when the current Power, Power Consumption or Current is over the threshold value.</p>
2	Retransmit	5	General: NA	Retransmit a Basic Set, Binary Switch Set or Scene Activation Set to the nodes associated.

4.10 Configuration

Note: R=Read Only, W=Write Only, WR=Write and Read.

Parameter	Description	W/R	Default	Size								
0x04(4)	<p>Over-load protection. Define a threshold power and automatically turn off switch when the load connected bypasses the maximum allowed power regardless of always on setting.</p> <table border="1"> <thead> <tr> <th>Value</th> <th>Description</th> </tr> </thead> <tbody> <tr> <td>0</td> <td>Disable over-load protection</td> </tr> <tr> <td>1..2415</td> <td>Threshold power is 1-2145W</td> </tr> </tbody> </table> <p>Note: Over-load protection will be active if the load power exceeds the setting and lasts for more than 30s. If be active, Indicator Light will become red light blinking and the product will send out Notification Report (Over-load detected), and disable the function that manually or RF control the switch state until users set Protection State to be unprotected through the Gateway or Controller. Even power off will still keep Protection State.</p>	Value	Description	0	Disable over-load protection	1..2415	Threshold power is 1-2145W	WR	0x096F (2415W)	2		
Value	Description											
0	Disable over-load protection											
1..2415	Threshold power is 1-2145W											
0x08(8)	<p>Alarm Response. Enabled by (Alarm Settings), and determines what the switch does in the case an alarm is triggered.</p> <table border="1"> <thead> <tr> <th>Value</th> <th>Description</th> </tr> </thead> <tbody> <tr> <td>0</td> <td>Disable, no reaction to alarm settings</td> </tr> <tr> <td>1</td> <td>Switch is ON</td> </tr> <tr> <td>2</td> <td>Switch is OFF</td> </tr> </tbody> </table>	Value	Description	0	Disable, no reaction to alarm settings	1	Switch is ON	2	Switch is OFF	WR	0	1
Value	Description											
0	Disable, no reaction to alarm settings											
1	Switch is ON											
2	Switch is OFF											

	<p>3 Switch will turn ON in 5 seconds, and then turn OFF in 5 seconds in a cycle until user disables the alarm manually</p> <p>Note: When receives any alarm enabled by Alarm Settings, Indicator Light will keep blinking based on Parameter 0x12 (18). It will prohibit user from manually or RF control the switch state until the alarm is disable.</p>																																																																												
0x09(9)	<p>Alarm Settings. Determine if alarms are enabled in Switch, and what Switch will react to which alarm. The format of the parameter is Bit field (Checkboxes). The parameter MUST be treated as a bit field where each individual bit can be set or reset. A graphical configuration tool SHOULD present this parameter as a series of checkboxes.</p> <table border="1" data-bbox="252 517 1192 736"> <thead> <tr> <th></th> <th>7</th> <th>6</th> <th>5</th> <th>4</th> <th>3</th> <th>2</th> <th>1</th> <th>0</th> </tr> </thead> <tbody> <tr> <td>Value1</td> <td>Reserved</td> <td>Home Security</td> <td>Access Control</td> <td>Water Alarm</td> <td>Heart Alarm</td> <td>CO2 Alarm</td> <td>CO Alarm</td> <td>Smoke Alarm</td> </tr> <tr> <td>Value2</td> <td colspan="7">Reserved</td> <td>Access Control trigger state</td> </tr> </tbody> </table> <p>Value1: Supported Notification Type and Notification Event</p> <table border="1" data-bbox="252 795 1165 1570"> <thead> <tr> <th>Value</th> <th>Notification Type</th> <th>Notification Event</th> </tr> </thead> <tbody> <tr> <td rowspan="3">1</td> <td rowspan="3">Smoke Alarm</td> <td>State idle</td> </tr> <tr> <td>Smoke detected (location provided)</td> </tr> <tr> <td>Smoke detected</td> </tr> <tr> <td rowspan="3">2</td> <td rowspan="3">CO Alarm</td> <td>State idle</td> </tr> <tr> <td>Carbon monoxide detected (location provided)</td> </tr> <tr> <td>Carbon monoxide detected</td> </tr> <tr> <td rowspan="3">4</td> <td rowspan="3">CO2 Alarm</td> <td>State idle</td> </tr> <tr> <td>Carbon dioxide detected (location provided)</td> </tr> <tr> <td>Carbon dioxide detected</td> </tr> <tr> <td rowspan="3">8</td> <td rowspan="3">Heart Alarm</td> <td>State idle</td> </tr> <tr> <td>Overheat detected (location provided)</td> </tr> <tr> <td>Overheat detected</td> </tr> <tr> <td rowspan="3">16</td> <td rowspan="3">Water Alarm</td> <td>State idle</td> </tr> <tr> <td>Water leak detected (location provided)</td> </tr> <tr> <td>Water leak detected</td> </tr> <tr> <td rowspan="3">32</td> <td rowspan="3">Access Control</td> <td>State idle</td> </tr> <tr> <td>Window/door is open</td> </tr> <tr> <td>Window/door is closed</td> </tr> <tr> <td rowspan="5">64</td> <td rowspan="5">Home Security</td> <td>State idle</td> </tr> <tr> <td>Intrusion (location provided)</td> </tr> <tr> <td>Intrusion</td> </tr> <tr> <td>Motion detection (location provided)</td> </tr> <tr> <td>Motion detection</td> </tr> </tbody> </table> <p>Value2: Access Control trigger state:</p> <table border="1" data-bbox="252 1628 1165 1783"> <thead> <tr> <th>Value</th> <th>Description</th> </tr> </thead> <tbody> <tr> <td>0</td> <td>Alarm will be triggered by open state, and be disable by closed state or idle state</td> </tr> <tr> <td>1</td> <td>Alarm will be triggered by closed state, and be disable by open state or idle state</td> </tr> </tbody> </table> <p>Example: If the parameter value equals to 8704(0x2200), Alarm Response will active when receives Carbon monoxide detected or Window/door is open. If the parameter value equals to 8705(0x2201), Alarm Response will active when receives Carbon monoxide detected or Window/door is Closed.</p>		7	6	5	4	3	2	1	0	Value1	Reserved	Home Security	Access Control	Water Alarm	Heart Alarm	CO2 Alarm	CO Alarm	Smoke Alarm	Value2	Reserved							Access Control trigger state	Value	Notification Type	Notification Event	1	Smoke Alarm	State idle	Smoke detected (location provided)	Smoke detected	2	CO Alarm	State idle	Carbon monoxide detected (location provided)	Carbon monoxide detected	4	CO2 Alarm	State idle	Carbon dioxide detected (location provided)	Carbon dioxide detected	8	Heart Alarm	State idle	Overheat detected (location provided)	Overheat detected	16	Water Alarm	State idle	Water leak detected (location provided)	Water leak detected	32	Access Control	State idle	Window/door is open	Window/door is closed	64	Home Security	State idle	Intrusion (location provided)	Intrusion	Motion detection (location provided)	Motion detection	Value	Description	0	Alarm will be triggered by open state, and be disable by closed state or idle state	1	Alarm will be triggered by closed state, and be disable by open state or idle state	WR	0	2
	7	6	5	4	3	2	1	0																																																																					
Value1	Reserved	Home Security	Access Control	Water Alarm	Heart Alarm	CO2 Alarm	CO Alarm	Smoke Alarm																																																																					
Value2	Reserved							Access Control trigger state																																																																					
Value	Notification Type	Notification Event																																																																											
1	Smoke Alarm	State idle																																																																											
		Smoke detected (location provided)																																																																											
		Smoke detected																																																																											
2	CO Alarm	State idle																																																																											
		Carbon monoxide detected (location provided)																																																																											
		Carbon monoxide detected																																																																											
4	CO2 Alarm	State idle																																																																											
		Carbon dioxide detected (location provided)																																																																											
		Carbon dioxide detected																																																																											
8	Heart Alarm	State idle																																																																											
		Overheat detected (location provided)																																																																											
		Overheat detected																																																																											
16	Water Alarm	State idle																																																																											
		Water leak detected (location provided)																																																																											
		Water leak detected																																																																											
32	Access Control	State idle																																																																											
		Window/door is open																																																																											
		Window/door is closed																																																																											
64	Home Security	State idle																																																																											
		Intrusion (location provided)																																																																											
		Intrusion																																																																											
		Motion detection (location provided)																																																																											
		Motion detection																																																																											
Value	Description																																																																												
0	Alarm will be triggered by open state, and be disable by closed state or idle state																																																																												
1	Alarm will be triggered by closed state, and be disable by open state or idle state																																																																												
0x0A(10)	<p>Setting to disable alarm. Determines the method of disabling the alarm of the device.</p> <table border="1" data-bbox="252 2027 1165 2058"> <thead> <tr> <th>Value</th> <th>Description</th> </tr> </thead> <tbody> </tbody> </table>	Value	Description	WR	0	2																																																																							
Value	Description																																																																												

	<table border="1"> <tr> <td>0</td> <td>Can be disabled by 3x tapping Action Button within 1 second</td> </tr> <tr> <td>1</td> <td>Can be disabled when receives a State Idle corresponding to the alarm. Note: If Access Control is enable, it also can be disabled when receives the reversal state of window/door.</td> </tr> <tr> <td>10..255</td> <td>Sets the duration of the alarm in seconds(i.e. Customer sets this setting to 50, the alarm state of the Switch will disable after 50 seconds)</td> </tr> </table> <p>Note: Power off will also disable the alarm response without any limitation.</p>	0	Can be disabled by 3x tapping Action Button within 1 second	1	Can be disabled when receives a State Idle corresponding to the alarm. Note: If Access Control is enable, it also can be disabled when receives the reversal state of window/door.	10..255	Sets the duration of the alarm in seconds(i.e. Customer sets this setting to 50, the alarm state of the Switch will disable after 50 seconds)					
0	Can be disabled by 3x tapping Action Button within 1 second											
1	Can be disabled when receives a State Idle corresponding to the alarm. Note: If Access Control is enable, it also can be disabled when receives the reversal state of window/door.											
10..255	Sets the duration of the alarm in seconds(i.e. Customer sets this setting to 50, the alarm state of the Switch will disable after 50 seconds)											
0x12(18)	<p>LED blinking frequency.</p> <table border="1"> <thead> <tr> <th>Value</th> <th>Description</th> </tr> </thead> <tbody> <tr> <td>1..9</td> <td>Set amount of blinks per seconds.</td> </tr> </tbody> </table> <p>Note: When receiving the enable Alarm, it will flash according to the blink frequency configured by this parameter until the Alarm is disable. Brightness level and color is based on current indicator. If the value of brightness level and color is 0, it will flash based on last visible color.</p>	Value	Description	1..9	Set amount of blinks per seconds.	WR	2	1				
Value	Description											
1..9	Set amount of blinks per seconds.											
0x13(19)	<p>Start or stop LED blinking.(Write Only)</p> <table border="1"> <thead> <tr> <th>Value</th> <th>Description</th> </tr> </thead> <tbody> <tr> <td>0</td> <td>Stop blinking.</td> </tr> <tr> <td>1..255</td> <td>Set the duration and start the blinking process. * This sets the timeframe of blinking in seconds. * Once the duration ends, the blinking will stop.</td> </tr> </tbody> </table> <p>Note: The parameter can be used to test the effect of LED blinking.</p>	Value	Description	0	Stop blinking.	1..255	Set the duration and start the blinking process. * This sets the timeframe of blinking in seconds. * Once the duration ends, the blinking will stop.	W	-	2		
Value	Description											
0	Stop blinking.											
1..255	Set the duration and start the blinking process. * This sets the timeframe of blinking in seconds. * Once the duration ends, the blinking will stop.											
0x14(20)	<p>Action in case of power out.</p> <table border="1"> <thead> <tr> <th>Value</th> <th>Description</th> </tr> </thead> <tbody> <tr> <td>0</td> <td>Last status</td> </tr> <tr> <td>1</td> <td>Switch is on</td> </tr> <tr> <td>2</td> <td>Switch is off</td> </tr> </tbody> </table>	Value	Description	0	Last status	1	Switch is on	2	Switch is off	WR	0	1
Value	Description											
0	Last status											
1	Switch is on											
2	Switch is off											
0x50(80)	<p>Configure what command will be sent via Lifeline when switch state has changed.</p> <table border="1"> <thead> <tr> <th>Value</th> <th>Description</th> </tr> </thead> <tbody> <tr> <td>0</td> <td>None</td> </tr> <tr> <td>1</td> <td>Basic Report</td> </tr> <tr> <td>2</td> <td>Binary Switch Report</td> </tr> </tbody> </table>	Value	Description	0	None	1	Basic Report	2	Binary Switch Report	WR	2	1
Value	Description											
0	None											
1	Basic Report											
2	Binary Switch Report											
0x51(81)	<p>Load Indicator Mode setting.</p> <table border="1"> <thead> <tr> <th>Value</th> <th>Description</th> </tr> </thead> <tbody> <tr> <td>0</td> <td>Disable Mode. * LED will only illuminate for network removal, press and hold Action Button. * No other LED reaction for load status. * Will allow LED blinking frequency parameter setting to blink the LED. * Brightness level can NOT be configured via Multilevel Switch CC. * Color can NOT be configured via Color Switch CC. * Will report Application Rejected Request when receives Multilevel Switch CC or Color Switch CC.</td> </tr> <tr> <td>1</td> <td>Night Light Mode. * During enable time, 100% Red is the default color and can be changed. * During disable time, OFF is the default color and can be changed. * Enable and disable time are defined by Parameter 0x52(82). * Brightness level can be configured via Multilevel Switch CC. * Color can be configured via Color Switch CC.</td> </tr> <tr> <td>2</td> <td>ON/OFF Mode. * ON status, 50% White is the default color and can be changed. * OFF status, 10% Green is the default color and can be changed. * Brightness level can be configured via Multilevel Switch CC. * Color can be configured via Color Switch CC.</td> </tr> </tbody> </table> <p>Note: Configuring brightness and color of Indicator Light in different time/status of different modes will be saved in the current setting mode.</p>	Value	Description	0	Disable Mode. * LED will only illuminate for network removal, press and hold Action Button. * No other LED reaction for load status. * Will allow LED blinking frequency parameter setting to blink the LED. * Brightness level can NOT be configured via Multilevel Switch CC. * Color can NOT be configured via Color Switch CC. * Will report Application Rejected Request when receives Multilevel Switch CC or Color Switch CC.	1	Night Light Mode. * During enable time, 100% Red is the default color and can be changed. * During disable time, OFF is the default color and can be changed. * Enable and disable time are defined by Parameter 0x52(82). * Brightness level can be configured via Multilevel Switch CC. * Color can be configured via Color Switch CC.	2	ON/OFF Mode. * ON status, 50% White is the default color and can be changed. * OFF status, 10% Green is the default color and can be changed. * Brightness level can be configured via Multilevel Switch CC. * Color can be configured via Color Switch CC.	WR	2	1
Value	Description											
0	Disable Mode. * LED will only illuminate for network removal, press and hold Action Button. * No other LED reaction for load status. * Will allow LED blinking frequency parameter setting to blink the LED. * Brightness level can NOT be configured via Multilevel Switch CC. * Color can NOT be configured via Color Switch CC. * Will report Application Rejected Request when receives Multilevel Switch CC or Color Switch CC.											
1	Night Light Mode. * During enable time, 100% Red is the default color and can be changed. * During disable time, OFF is the default color and can be changed. * Enable and disable time are defined by Parameter 0x52(82). * Brightness level can be configured via Multilevel Switch CC. * Color can be configured via Color Switch CC.											
2	ON/OFF Mode. * ON status, 50% White is the default color and can be changed. * OFF status, 10% Green is the default color and can be changed. * Brightness level can be configured via Multilevel Switch CC. * Color can be configured via Color Switch CC.											
0x52(82)	Configure the enable and disable time of Night Light Mode	WR	0x12000800	4								

	<table border="1"> <tr> <th>7</th> <th>6</th> <th>5</th> <th>4</th> <th>3</th> <th>2</th> <th>1</th> <th>0</th> </tr> <tr> <td colspan="8">Value1: Enable Hour</td> </tr> <tr> <td colspan="8">Value2: Enable Minute</td> </tr> <tr> <td colspan="8">Value3: Disable Hour</td> </tr> <tr> <td colspan="8">Value4: Disable Minute</td> </tr> </table> <p>Enable Hour: Valid value are 0-23 and 127. Value 127 means use last valid setting.</p> <p>Enable Minute: Valid value are 0-59 and 255. Value 255 means use last valid setting.</p> <p>Disable Hour: Valid value are 0-23 and 255. Value 255 means use last valid setting.</p> <p>Disable Minute: Valid value are 0-59 and 255. Value 255 means use last valid setting.</p> <p>Example: If you want to set Night Light Mode to be enable at 19:00 at night and disable at 07:30 in the morning, you just need to configure: Value1=0x13, Value2=0x00, Value3=0x07, Value4=0x1E.</p>	7	6	5	4	3	2	1	0	Value1: Enable Hour								Value2: Enable Minute								Value3: Disable Hour								Value4: Disable Minute										
7	6	5	4	3	2	1	0																																					
Value1: Enable Hour																																												
Value2: Enable Minute																																												
Value3: Disable Hour																																												
Value4: Disable Minute																																												
0x5B(91)	<p>Threshold Power (W) for inducing automatic report.</p> <table border="1"> <thead> <tr> <th>Value</th> <th>Description</th> </tr> </thead> <tbody> <tr> <td>0</td> <td>Disable</td> </tr> <tr> <td>1..2300</td> <td>1-2300W</td> </tr> </tbody> </table>	Value	Description	0	Disable	1..2300	1-2300W	WR	0	2																																		
Value	Description																																											
0	Disable																																											
1..2300	1-2300W																																											
0x5C(92)	<p>Threshold Power Consumption (kWh) for inducing automatic report.</p> <table border="1"> <thead> <tr> <th>Value</th> <th>Description</th> </tr> </thead> <tbody> <tr> <td>0</td> <td>Disable</td> </tr> <tr> <td>1..10000</td> <td>1-10000kWh</td> </tr> </tbody> </table>	Value	Description	0	Disable	1..10000	1-10000kWh	WR	0	2																																		
Value	Description																																											
0	Disable																																											
1..10000	1-10000kWh																																											
0x5D(93)	<p>Threshold Current (A) for inducing automatic report.</p> <table border="1"> <thead> <tr> <th>Value</th> <th>Description</th> </tr> </thead> <tbody> <tr> <td>0</td> <td>Disable</td> </tr> <tr> <td>1..100</td> <td>0.1-10A. Unit is 0.1A.</td> </tr> </tbody> </table>	Value	Description	0	Disable	1..100	0.1-10A. Unit is 0.1A.	WR	0	1																																		
Value	Description																																											
0	Disable																																											
1..100	0.1-10A. Unit is 0.1A.																																											
0x65(101)	<p>Configure which meter reading will be periodically report via Lifeline.</p> <table border="1"> <tr> <th>7</th> <th>6</th> <th>5</th> <th>4</th> <th>3</th> <th>2</th> <th>1</th> <th>0</th> </tr> <tr> <td colspan="8">Reserved</td> </tr> <tr> <td colspan="8">Reserved</td> </tr> <tr> <td colspan="8">Reserved</td> </tr> <tr> <td colspan="4">Reserved</td> <td>Current</td> <td>Voltage</td> <td>Power</td> <td>Power Consumption</td> </tr> </table> <p>The format of the parameter is Bit field (Checkboxes). The parameter MUST be treated as a bit field where each individual bit can be set or reset. A graphical configuration tool SHOULD present this parameter as a series of checkboxes.</p> <p>Note: The sending frequency is related to Configuration Parameter 0x6F (111).</p>	7	6	5	4	3	2	1	0	Reserved								Reserved								Reserved								Reserved				Current	Voltage	Power	Power Consumption	WR	0x0000000F	4
7	6	5	4	3	2	1	0																																					
Reserved																																												
Reserved																																												
Reserved																																												
Reserved				Current	Voltage	Power	Power Consumption																																					
0x6F(111)	<p>Configure the sending frequency of Meter Report.</p> <table border="1"> <thead> <tr> <th>Value</th> <th>Description</th> </tr> </thead> <tbody> <tr> <td>0</td> <td>Disable</td> </tr> <tr> <td>600..2592000</td> <td>600-2592000s. (10minute-30day)</td> </tr> </tbody> </table>	Value	Description	0	Disable	600..2592000	600-2592000s. (10minute-30day)	WR	0x00000258 (600s)	4																																		
Value	Description																																											
0	Disable																																											
600..2592000	600-2592000s. (10minute-30day)																																											
0xFF(255)	<p>Factory Reset or Initialization (Write Only)</p> <table border="1"> <thead> <tr> <th>Value</th> <th>Description</th> </tr> </thead> <tbody> <tr> <td>1431655765 (0x55555555)</td> <td>Factory Reset: Restore the product to factory settings and remove from the network.</td> </tr> <tr> <td>Other</td> <td>Initialization: Initialize all configuration parameters to default values.</td> </tr> </tbody> </table>	Value	Description	1431655765 (0x55555555)	Factory Reset: Restore the product to factory settings and remove from the network.	Other	Initialization: Initialize all configuration parameters to default values.	W	-	4																																		
Value	Description																																											
1431655765 (0x55555555)	Factory Reset: Restore the product to factory settings and remove from the network.																																											
Other	Initialization: Initialize all configuration parameters to default values.																																											