

Tools needed

To mount the Danalock you need a Philips screwdriver and two pliers or a wire cutter.

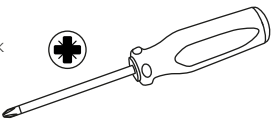

Parts involved on your existing lock

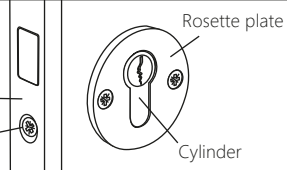

Contents of the Danalock box you'll need for the easy install

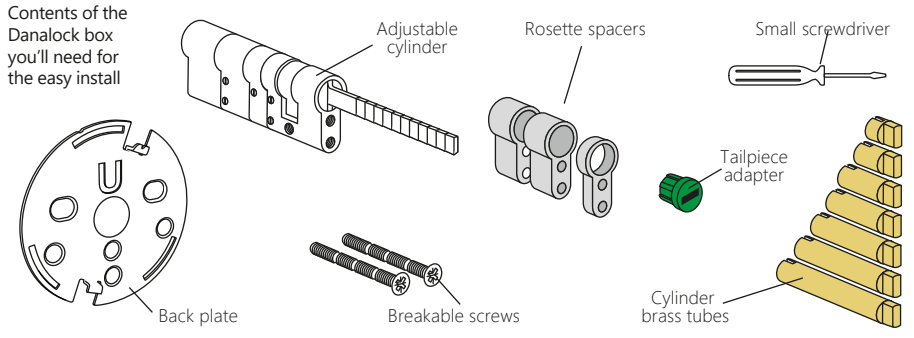

1. Remove the old cylinder

First you have to remove your current cylinder.

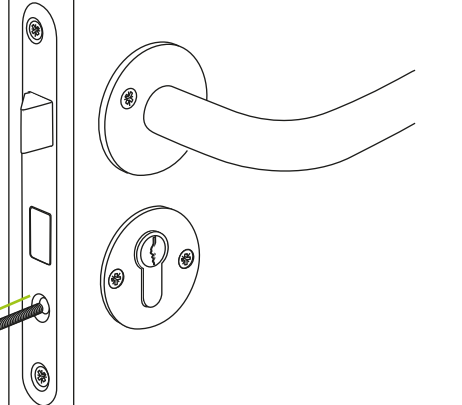

Unscrew the lock-screw in the mortise-plate on the side of the door.

2. Pull out the old cylinder

Insert your key and turn it so the cam lines up with the body of the cylinder. Then it will be easy to pull out of the hole in the rosette.

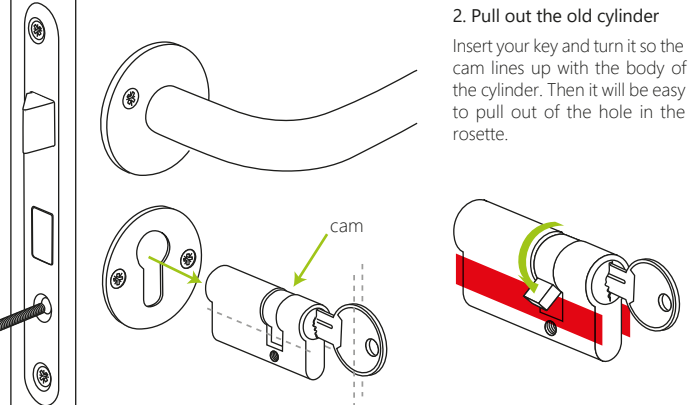

3. Adjust the new cylinder

Measure the back part (on the outside of your door) of the old cylinder from the middle of the screwhole and away (see illustration).

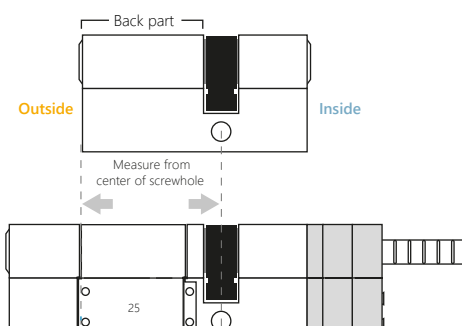

In the Danalock box you'll find an adjustable lock cylinder.

4. Just unscrew the small screws on both sides of the part you want to remove, and pull the cylinder apart.

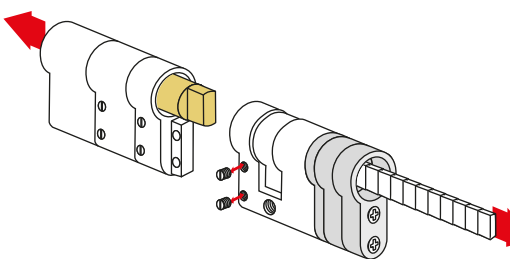

5. Insert new brass tube and spacer piece

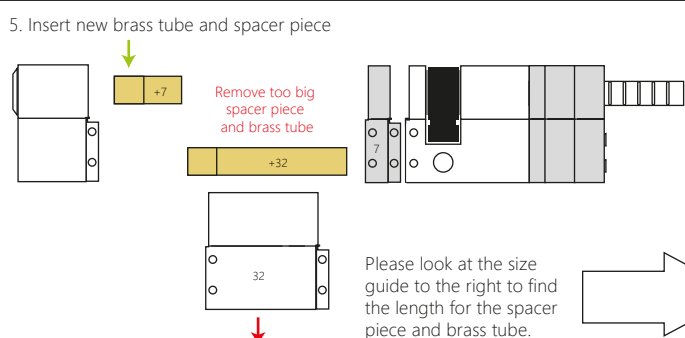

Remove too big spacer piece and brass tube

Please look at the size guide to the right to find the length for the spacer piece and brass tube.

6. Assemble the cylinder and screw the tiny screws back in on both sides of the cylinder.

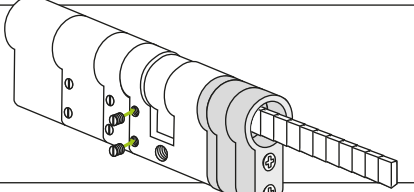

7. Size guide

When you remove one or more parts of the cylinder you'll have to exchange the brass tube in the center with another that fits the new measurements.

Here is the different combinations.

Fits min. 35 mm		=
Fits min. 40 mm		=
Fits min. 45 mm		=
Fits min. 50 mm		=
Fits min. 55 mm		=
Fits min. 60 mm		=

The adjustable cylinder as it is in the box



8. Insert the adjustable cylinder

Insert the new cylinder, and re-insert the lock-screw in the mortise-plate to fix the cylinder. (b)

Do not tighten the screw to hard - make sure the cylinder is working by locking and unlocking with your hand.

9. The right Rosette spacer

To avoid pulling the cylinder out of place you need to find the right spacer between the rosette and the new cylinder.

Unscrew the breakable screws that holds the spacers together to the adjustable cylinder, and choose the spacer with the same or larger thickness than the gap between the cylinder and the rosette surface. (a)

IMPORTANT!

Avoid pulling the cylinder out of place

It is important that the spacer flushes or sticks out from the hole in the rosette plate.

10. Break the screws the right length

If you don't need all 3 spacers between the cylinder and the rosette you have to break or cut the cylinder screws so they fit the distance.

Use a wirecutter, two pliers or bend the screws forth and back several times in a vice to break them.

11. Fasten the back plate to the cylinder

Now fasten the back plate to the cylinder with the mortise spacer between them.

IMPORTANT! Check that the lock still works!

Make sure that the lock still works properly by turning the tailpiece. If you can't lock and unlock this way please loosen the cylinder screws. (b)

12. Give the tailpiece the right length

To avoid damaging the danalock you will have to shorten the new cylinder tailpiece to max. 35 mm from the door surface.

Use two pliers or a wire cutter to shorten the tailpiece.

13. Attach the tailpiece adaptor

Insert the green tailpiece adaptor in the center tube on the backside of the Danalock.

Press on the adaptor until a click ensures it is fixed firmly to the Danalock.



14. Fit the tailpiece to the middle of the housing base

Fit the Danalock over the back plate.
Make sure the tailpiece hits the slide in the middle of the adaptor.

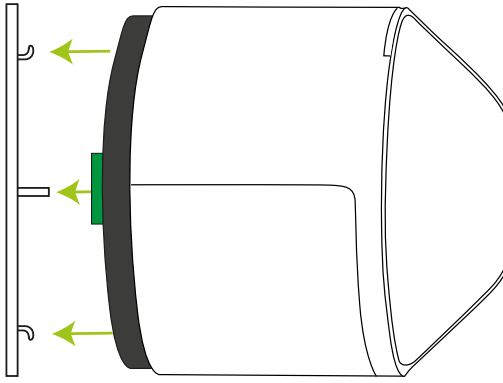

15. Align the platemarks

Find the small marking on the edge of the backplate and align the mark on the back of the Danalock baseplate with it.
Now you are sure to hit the notches on the backplate with the Danalock.

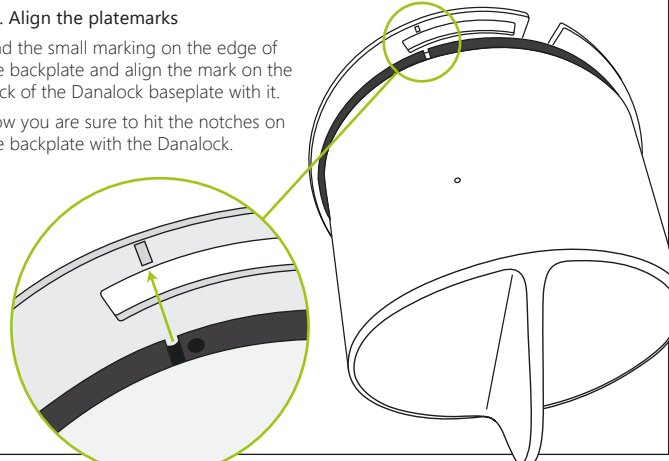

16. Fasten the Danalock

Turn the Danalock clockwise until it clicks to fasten it to the back plate.

Click!

NOTE: If you need to unfasten and retry, see "Uninstall instructions" at the end of the manual.

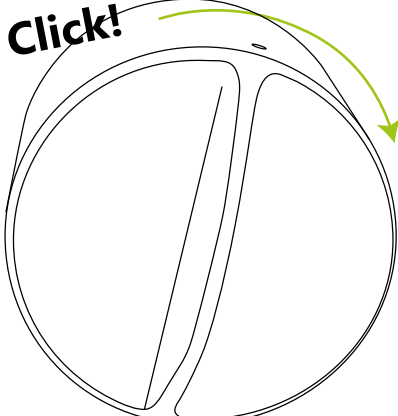

17. Activate batteries

Pull out the plastic tab to activate the batteries.
A light will flash to confirm the Danalock is ready.

Note: If the batteries are disconnected, you will have to re-calibrate the Danalock.

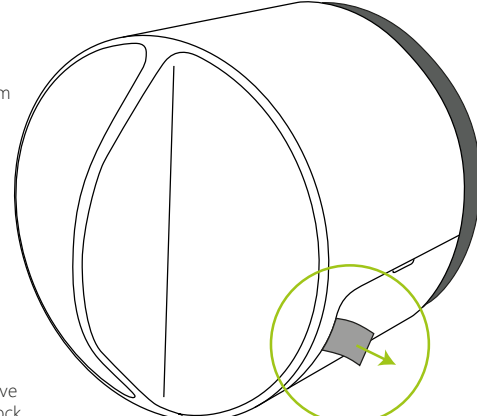

18. Before downloading the app

Your Danalock is now attached to the door. Download and open the Danalock app to finish setting it up.
Leave the door open, so the lock isn't influenced when calibrated.

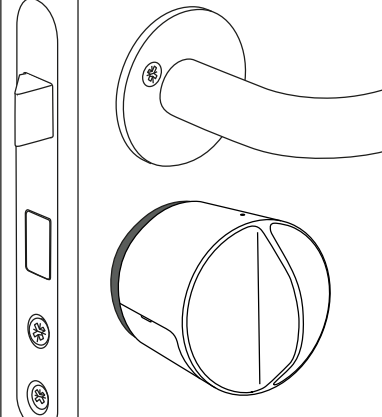

19. Download the Danalock App

Go to Google Play or App Store and download the Danalock App.
When the app is installed you create a user profile by pressing the blue ring. You will use this profile each time you sign into the app.

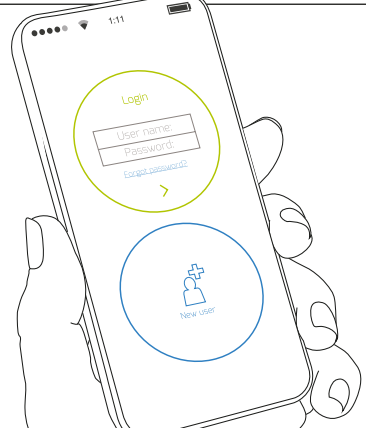

20. Add the lock in the app

You now need to add your Danalock in the app.
Press "Add lock" at the bottom of the screen. A guide will lead you through the installation and configuration of your Danalock.

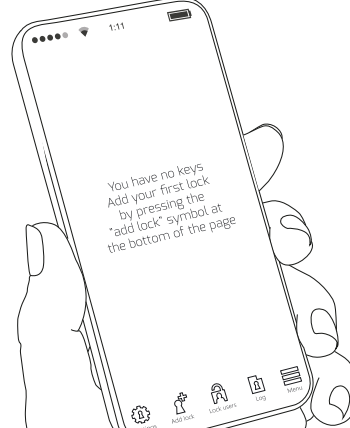

21. Dismount instructions

If at any time you need to dismount the Danalock from your door, insert a pen tip into the hole at the top inner edge of the lock and press while turning the lock counter-clockwise until the lock releases.

This will not reset the lock or disconnect it from your account, but the lock may need to be re-calibrated if fastened to your door again.

