

# Air Quality Sensor Z-Wave Plus

Installation & Operation Guide



# Content

---

1	Included in delivery	3	8	Association	10
2	Safety Instructions	4	9	Configuration	10
3	Intended Use	4	10	Multilevel Sensor	11
4	Product description	5	11	Notification	11
5	Operating the device	6	12	Troubleshooting	12
5.1	Button	6			
5.2	LEDs	6	13	Cleaning	12
6	Network behavior	7	14	Technical specifications	12
6.1	Power supply	8			
6.2	Add to a Z-Wave network (Inclusion)	8	15	Disposal	13
6.3	Remove from a Z-Wave network (Exclusion)	8			
6.4	Factory reset	9	16	Warranty	13
7	Z-Wave	9	17	Contact information	13

# 1. Included in delivery

---

**1 x Air Quality Sensor Z-Wave Plus**

**1 x Micro USB power supply**

**1 x Quick Start Manual**

**NOTE!** The following figures are for illustration purposes only and may differ from the actual product.

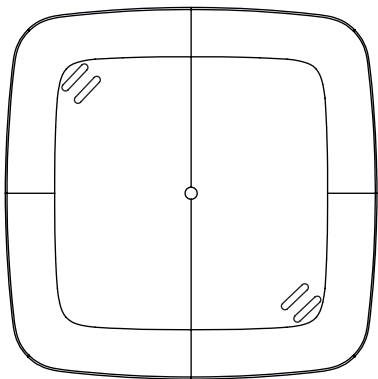

**Air Quality Sensor Z-Wave Plus**

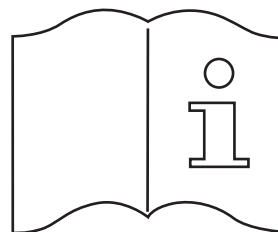

**Quick Start Manual**

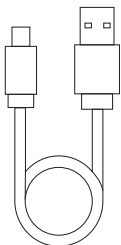

**Micro USB power supply**

**NOTE!** Please check the scope of delivery for completeness and intactness.

## 2. Safety Instructions

---

Avoid potential dangers by reading the following safety instructions carefully.

### **SAFETY INSTRUCTIONS**

- Air Quality Sensor Z-Wave Plus is designed for use in buildings.
- Operate Air Quality Sensor Z-Wave Plus only as described in the user manual.
- Air Quality Sensor Z-Wave Plus should only be put to use in a dry and dust-free place, away from direct sunlight.
- Do not keep using the device when there is obvious damage.
- Air Quality Sensor Z-Wave Plus may not be rebuilt, modified or opened.

### **WARNING!**

Risk of fatal injury and accidents to infants and children! The packaging material represents a risk of suffocation. Never leave children unattended when the packaging material is nearby.

Children often underestimate the risks involved. Always keep children away from the packaging material. The device is not a toy.

## 3. Intended use

---

The product provides comprehensive information on indoor air quality.

For reasons of safety and approval (CE), you must not modify and/or alter the product. If you use the product for purposes other than those described, the product may be damaged. In addition, improper use may result in hazards such as short circuits, fire, electric shock, etc.

Read the operating instructions carefully and keep them in a safe place. Only pass the product on to third parties together with the operating instructions.

# 4. Product description

---

The brand new Z-Wave sensor in an ultra slim design housing provides comprehensive information on indoor air quality. Based on these information it is possible to always ensure a healthy living climate.

- Ultra-flat design housing
- Use of high-precision, Swiss sensor technology
- Multicolor LED for signalling ventilation recommendations
- Returns the following values:
  - VOC value (volatile organic compounds) in ppm
  - CO2 value (as CO2 equivalent) in ppm
  - Temperature (°C) and humidity (%)
  - Dew point (°C)
- Supports Z-Wave Plus S2 security (encryption)
- Z-Wave repeater function
- Operation with plug-in power supply unit

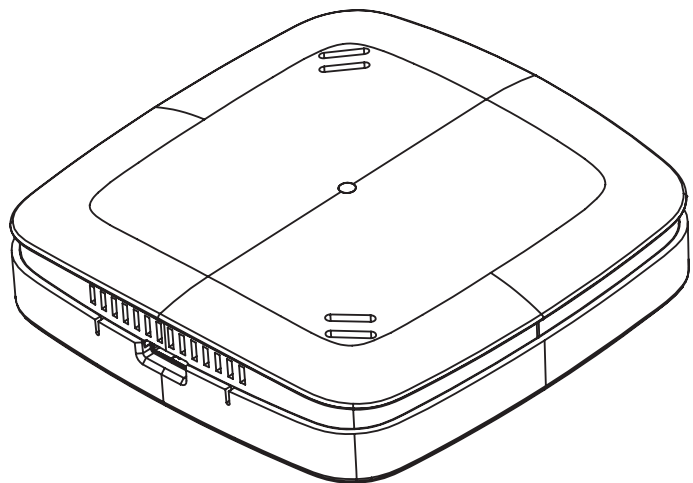

# 5. Operating the device

## 5.1 Button

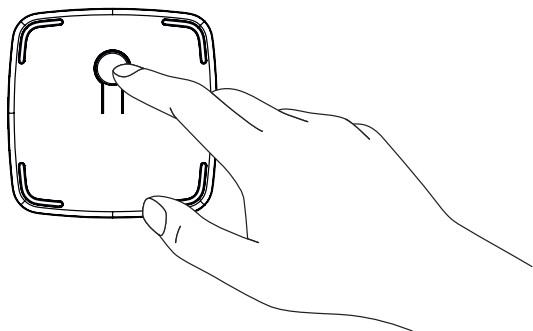

Button	Interaction	Result/Behavior
Network	press three times within 1 second	Air Quality Sensor Z-Wave Plus will react to inclusion or exclusion commands.
Network	hold for 10 seconds	Factory resets the Air Quality Sensor Z-Wave Plus.

## 5.2 LEDs

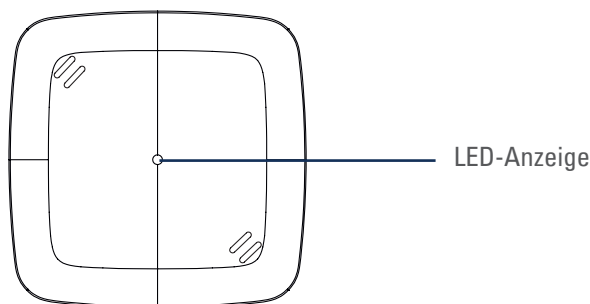

Color	State	Meaning
red	permanently illuminated	Air quality is bad. (LED signaling can be disabled via Configuration Command Class)
orange	permanently illuminated	Air quality is average. (LED signaling can be disabled via Configuration Command Class)
green	permanently illuminated	Air quality is good. (LED signaling can be disabled via Configuration Command Class)
red	lights constantly for 5 seconds	A task has failed.
green	blinking	Device is ready to be included or excluded.
green	lights constantly for 5 seconds	A task was completed successfully.
2x red 3x green	blinking pattern	LGS Z-Wave Plus is reset to factory default settings.

## 6. Network behavior

---

On factory default the device does not belong to any Z-Wave network. Air Quality Sensor Z-Wave Plus needs to be added to an existing wireless network to communicate with the devices of this network. This process is called Inclusion.

Air Quality Sensor Z-Wave Plus can also be removed from a network. This process is called Exclusion. Both processes are initiated by the primary controller of the Z-Wave network. This controller is turned into exclusion respective inclusion mode. Please consult the manual of your Z-Wave Controller how to activate Inclusion or Exclusion mode.

If Air Quality Sensor Z-Wave Plus has been added to a network, it has to be removed prior to be added to another wireless network.

### **Interoperability**

This product can be operated in any Z-Wave network with other Z-Wave certified devices from other manufacturers. All non-battery operated nodes within the network will act as repeaters regardless of vendor to increase reliability of the network.

### **Security**

Air Quality Sensor Z-Wave Plus supports secure communication. Air Quality Sensor Z-Wave Plus will communicate with other devices secure as long as this device provides the same or a higher level of security. Otherwise Air Quality Sensor Z-Wave Plus will automatically turn into a lower level of security.

A Security Enabled Z-Wave Controller must be used to fully utilize the Air Quality Sensor Z-Wave Plus.

## 6.1 Power supply

Connect the Micro-USB cable to a AC adapter and to the air quality sensor and afterwards to a power outlet.

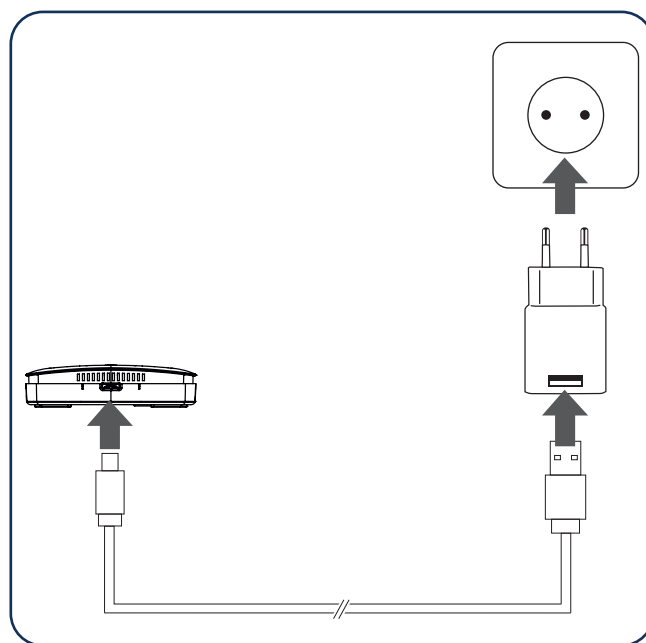
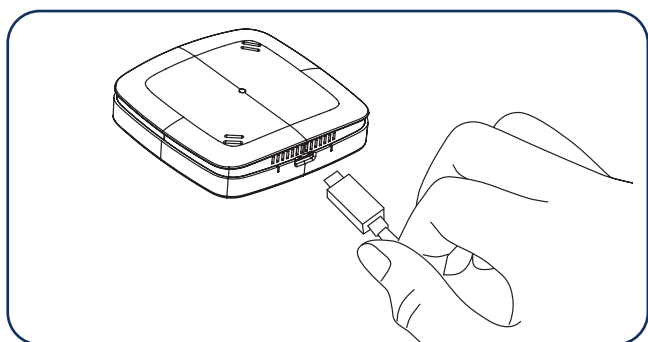

## 6.2 Add Air Quality Sensor Z-Wave Plus to a Z-Wave network

Start inclusion mode of your primary Z-Wave Controller.

Press the network button **three times within 1 second**.

While the inclusion is active, the LED is blinking green. If the inclusion was successful the green LED will light up for 5 seconds. Otherwise the red led will light up for 5 seconds to indicate failure.

## 6.3 Remove Air Quality Sensor Z-Wave Plus from a Z-Wave network

Start Exclusion mode of your primary Z-Wave Controller.

Press the network button **three times within 1 second**.

While the inclusion is active, the LED is blinking green. If the inclusion was successful the green LED will light up for 5 seconds. Otherwise the red led will light up for 5 seconds to indicate failure.



## 6.4 Factory reset

**Press and hold** the network button for at **least 10 seconds**. The Air Quality Sensor Z-Wave Plus will indicate the reset blinking pattern once the reset is completed.

Please use this procedure only when the network primary controller is missing or otherwise inoperable.

# 7. Z-Wave

Command Class	Description	Version	Control (C) Support (S)	Security *
Association	Allows to associate with other Z-Wave devices.	2	S	U, S0, S2
Association Group Information	Allows to group associations.	1	S	U, S0, S2
Configuration	Allows to configure the device settings.	1	S	U, S0, S2
Device Reset Locally	Informs the Z-Wave Controller that the device was factory reset.	1	S	U, S0, S2
Firmware Update Meta Data	Allows Over the Air Update of the device.	3	S	U, S0, S2
Manufacturer Specific	Provides information about manufacturer and product.	1	S	U, S0, S2
Multilevel Sensor	Provides sensor readings.	10	S	U, S0, S2
Notification	Informs the controller about system events.	8	S	U, S0, S2
Power Level	Used to alter the rf-power (required by Z-Wave).	1	S	U, S0, S2
Security	Allows encrypted Z-Wave communication.	2	S	U
Supervision	Transmits Z-Wave Commands with an execution confirmation.	1	S	U
Transport Service	Handles the transmission of large telegrams.	2	S	U
Version	Returns information about the firmware.	2	S	U, S0, S2
Z-Wave Plus Info	Identifies the device as a Z-Wave Plus device.	2	S	U

\* Availability of the Command Class after adding the Air Quality Sensor Z-Wave Plus to your Z-Wave network

U Unsecure

S0 Z-Wave Security standard S0

S2 Z-Wave Security standard S2

## 8. Association

Air Quality Sensor Z-Wave Plus can be associated with other devices.

Group No.	Description	Commands	Max supported Nodes
1	Lifeline	DEVICE_RESET_LOCALLY_NOTIFICATION, NOTIFICATION_REPORT, SENSOR_MULTILEVEL_REPORT,	1
2	Temperature	SENSOR_MULTILEVEL_REPORT	5

## 9. Configuration

Air Quality Sensor Z-Wave Plus can be configured during runtime.

Parameter number	Size in Byte	Name	Description
1	1	Temperature on Change Reporting	0x00 No on change reporting (only time-based reports). 0x01 - 0x32 report if temperature changed by delta = 0,1°C - 5,0°C <b>default: 0x05</b>
2	1	Humidity on Change Reporting	0x00 No on change reporting (only time-based reports). 0x01 - 0x0A report if humidity changed by delta = 1% ... 10% <b>default: 0x05</b>
3	1	Unit Temperature	0x00 Temperature reports in Celsius 0x01 Temperature reports in Fahrenheit <b>default: 0x00</b>
4	1	Resolution Temperature	0x00 No resolution (example 22°C) 0x01 1/10 resolution (example 22.3°C) 0x02 1/100 resolution (example 22.35°C) <b>default: 0x01</b>
5	1	Resolution Humidity	0x00 No resolution (example 33%) 0x01 1/10 resolution (example 33.4%) 0x02 1/100 resolution (example 33.45%) <b>default: 0x00</b>
6	1	VOC-on Change Reporting	0x00 No on change reporting (only time-based reports) 0x01 - 0x0A report if VOC reading changed by 100ppb - 1000ppb <b>default: 0x05</b>
7	1	CO <sub>2</sub> eq on Change Reporting	0x00 No on change reporting (only time-based reports) 0x01 - 0x0A report if CO <sub>2</sub> eq reading changed by 100ppm - 1000ppm <b>default: 0x05</b>
8	1	Air quality indication via LED	0x00 No air quality indication via LEDs 0x01 Indicate measured air quality via LEDs <b>default: 0x01</b>

# 10. Multilevel Sensor

---

Air Quality Sensor Z-Wave Plus measures the room temperature and automatically reports sensor readings to associated devices. Per default the reporting threshold is  $\pm 0.5^{\circ}\text{C}$ . This parameter can be altered via configuration command class.

**Sensor type:** „Air Temperature“  
**Scale:** Celsius and Fahrenheit  
**Precision:** 0,1 and 2

Air Quality Sensor Z-Wave Plus measures the humidity and automatically reports sensor readings to associated devices. Per default the reporting threshold is  $\pm 5\%$ . This parameter can be altered via configuration command class.

**Sensor type:** „Humidity“  
**Scale:** Prozent and absolut  
**Precision:** 0,1 and 2

Air Quality Sensor Z-Wave Plus measures the dewpoint and automatically reports sensor readings every 30 minutes to associated devices.

**Sensor type:** „Dewpoint“  
**Scale:** Celsius and Fahrenheit  
**Precision:** 1

Air Quality Sensor Z-Wave Plus measures the CO<sub>2</sub> concentration and automatically reports sensor readings to associated devices. Per default the reporting threshold is  $\pm 500\text{ppm}$ . This parameter can be altered via configuration command class.

**Sensor type:** „Carbon dioxide CO<sub>2</sub>-level“  
**Scale:** Parts/million (ppm)  
**Precision:** 0

Air Quality Sensor Z-Wave Plus measures the VOC concentration and automatically reports sensor readings to associated devices. Per default the reporting threshold is  $\pm 500\text{ppb}$ . This parameter can be altered via configuration command class.

**Sensor type:** „Volatile Organic Compound level“  
**Scale:** Parts/million (ppm)  
**Precision:** 3

# 11. Notification

---

Air Quality Sensor Z-Wave Plus will send notifications to the Z-Wave Controller.

Notification type	Reason	Description
Home Health	Air pollution level has changed	Pollution level 0x01: Clean 0x02: Slightly polluted 0x03: Moderately polluted 0x04: Highly polluted

# 12. Troubleshooting

---

Problem	Reason	Solution
red LED lights constantly for 5 seconds	A task has failed.	<ul style="list-style-type: none"><li>• Z-Wave Controller out of range.</li><li>• Repeat the task as needed.</li></ul>

# 13. Cleaning

---

**NOTE: RISK OF DAMAGE!** Improper handling of the Air Quality Sensor Z-Wave Plus can lead to damage.

- Do not immerse the Air Quality Sensor Z-Wave Plus in water or other liquids.
- Do not use aggressive cleaning agents, brushes with metal or nylon bristles or sharp or metallic cleaning objects such as knives, hard spatulas and the like. These can damage the surfaces.
- Clean the Air Quality Sensor Z-Wave Plus with a soft, dry cloth.

# 14. Technical specifications

---

Device description	Air Quality Sensor Z-Wave Plus	Method of operation	Type 1
EAN	42 600 127 112 64	Dimensions (WxHxD)	68 x 68 x 17 mm
Article Number	700088	Weight	47,7g
Supply Voltage	Power supply	Degree of protection	IP20
Radio Frequency	868,42 MHz	Degree of pollution	2
Output Power	+4dBm	Signalisierung	Multicolor-LED
		Color	white

Technical modifications are subject to change. All descriptions for compatibility are without engagement.

# 15. Disposal

---

## Advice on environmental protection:



From the date of implementation of European guidelines 2002/96/EC and 2006/66/EC, into national law, the following applies: Electric and electronic devices and batteries may not be disposed of in household waste. The consumer is obliged to return electric and electronic devices and batteries to the public collection points established for them or to the point of sale. The particulars of this are regulated by the applicable state laws. The symbol on the product, operation instructions or packaging points to these provisions. You make an important contribution to the protection of the environment by reusing or recycling old equipment/batteries or making use of them in other ways.

## Declaration of conformity:



Hereby, Eurotronic Technology GmbH declares that the Air Quality Sensor Z-Wave Plus is in compliance with Directive 2014/53/EU. The full text of the EU declaration of conformity is available at the following internet address: <https://eurotronic.org/service/downloads/>.

# 16. Warranty

---

The 24-months warranty period begins at the day of purchase. Please keep the receipt as evidence of purchase. During the warranty period, defective radiator thermostats may be sent to your dealer or the address below. Please ensure sufficient postage is paid. A new or repaired device will then be sent to you free of charge. No new warranty period begins with the repair or replacement of the device.

After the warranty period has expired, you also have the option of sending the defective device to the specified address with sufficient postage for repair. Repairs after the warranty period have expired are subject to a charge. Your statutory rights are not limited by this warranty.

# 17. Contact information

---

If you wish to receive further technical Support or information about other Eurotronic products, please contact us via E-Mail or telephone.

Eurotronic Technology GmbH  
Südweg 1  
36396 Steinau-Ulmbach  
Germany

Telephone: +49 (0) 6667 91847-0  
eMail: [info@eurotronic.org](mailto:info@eurotronic.org)  
Web: [www.eurotronic.org](http://www.eurotronic.org)